

# NAGA

User Manual (MX16 Version)

V1.0

2021.04



**FOXTECH**

# Contents

<b>Assembly</b>	3
Install Landing Gear	3
Unfold the Arm	5
Turn on Remote Controller	6
Install Battery	7
Install Propeller	9
<b>MX16 Use Part</b>	10
Remote controller Diagram	10
Air Unit Interface	12
Status Prompt Bar	12
MX16 Assistant	13
Frequency Pairing	14
Mode Changing	15
Channel Reverse	17
Image connection and setting	20
Joystick Calibration	21
Video Transmission Information Displayed on the Ground Station	21
Connect FC and Datalink in QGC	22
How to share network, video and data information.	23
<b>Mission Planner Basic Operation</b>	27
Download and Install Mission Planner	27
Connect with The Cube	28
Connect with The Cube	29
Basic Hardware Calibration and Parameter Setting	29
<b>Mission Planner RTK Setting</b>	39
Basic Settings	39
How to Use Base Station	42
<b>First Take-off</b>	43
Self-checking	43
Meaning of LED Indicator Light	43
First Flight	44
Take-off Precautions	46
<b>Automatic Mission Planning</b>	47
<b>How to Use Oblique Camera</b>	49
Camera Function Buttons	49
Camera and Aircraft Connection	49
Photo Taking Test	50
<b>FAQ</b>	53
<b>Troubleshooting Guide</b>	57
<b>How to Use QGC</b>	58

# Assembly

NAGA Herelink version accessories are shown in the following figure, including 1 NAGA drone, 2 pairs of propellers, 1 pair of landing gear, 1 set of remote control, 1 charger, 1 power battery, oblique camera 1 set (optional).



## Install Landing Gear

Take the landing gear out of the packing box and insert it into the metal parts on both sides of the body, then take the drone out of the packing box and stand on the ground.



Press the landing gear locking piece down firmly until the landing gear is locked in the metal piece.

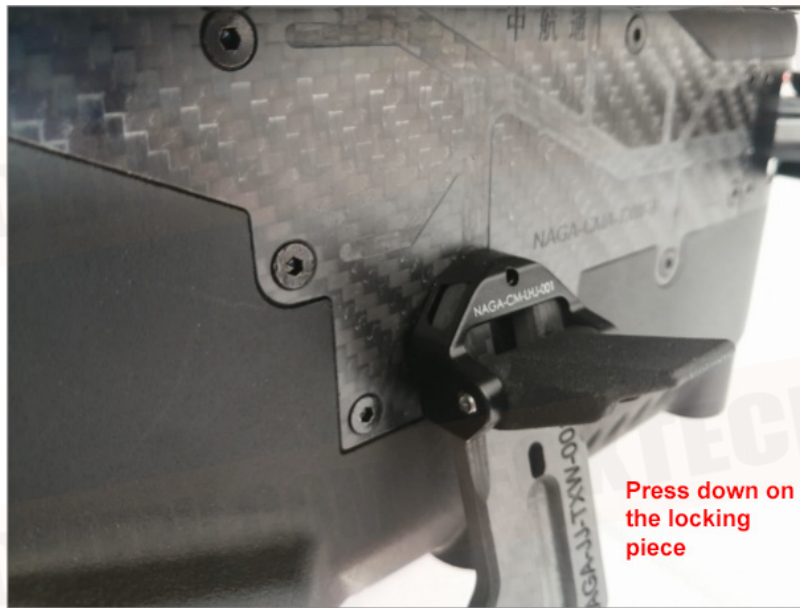

## Unfold the Arm

First unfold the lower arm of the fuselage around the rotation axis, and then unfold the upper arm, snap the arm buckle into the red locking piece, and turn the red locking piece clockwise to lock the arm.

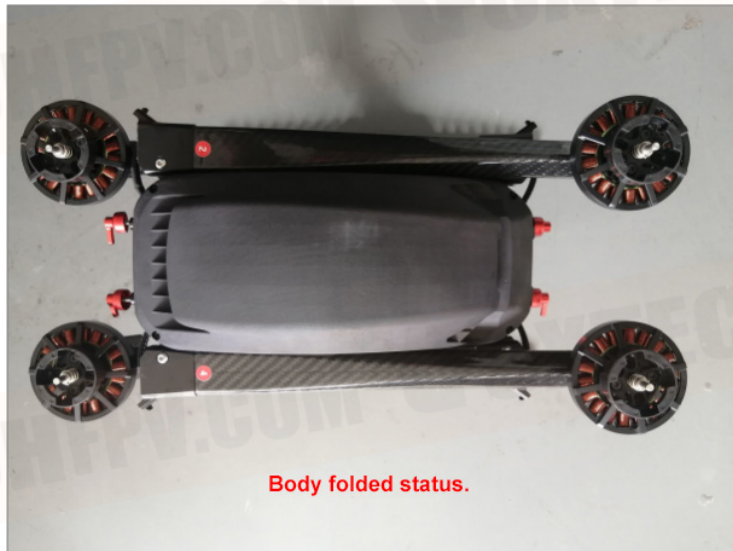

## Turn on Remote Controller

Take the remote control out of the shipping box, press and hold the power button to turn on the remote control, and then click the QGC icon on the screen to enter the ground station software.



## Install Battery

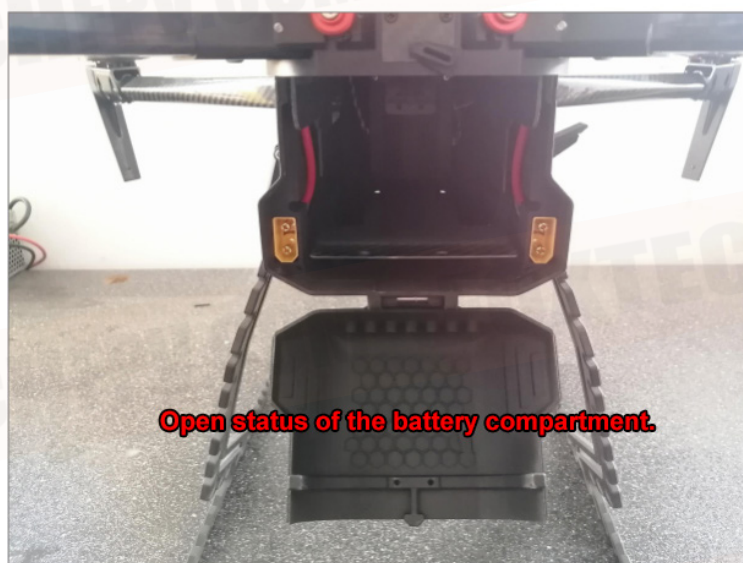

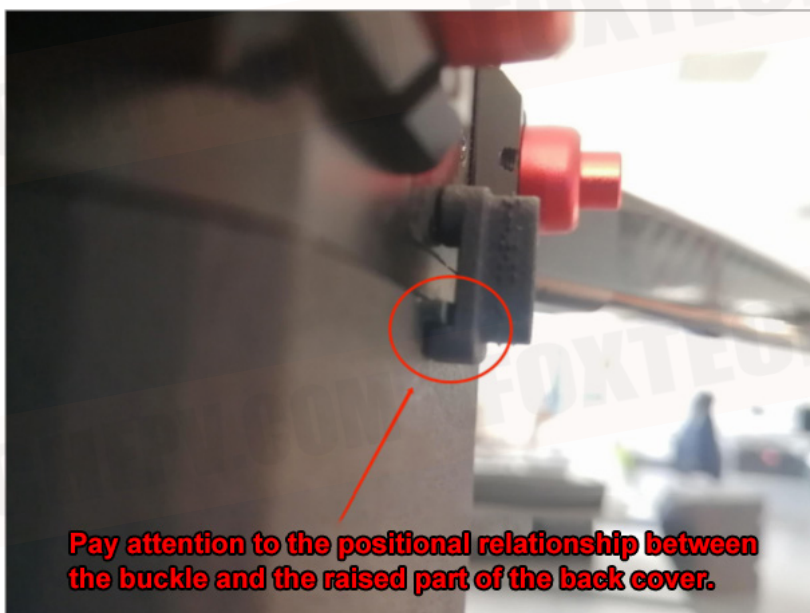



## Install Propeller

The installation method of NAGA two-motor propellers with diagonal symmetry is the same. The No. 1 and No. 3 arms are the same, and the No. 2 and No. 4 arms are the same.

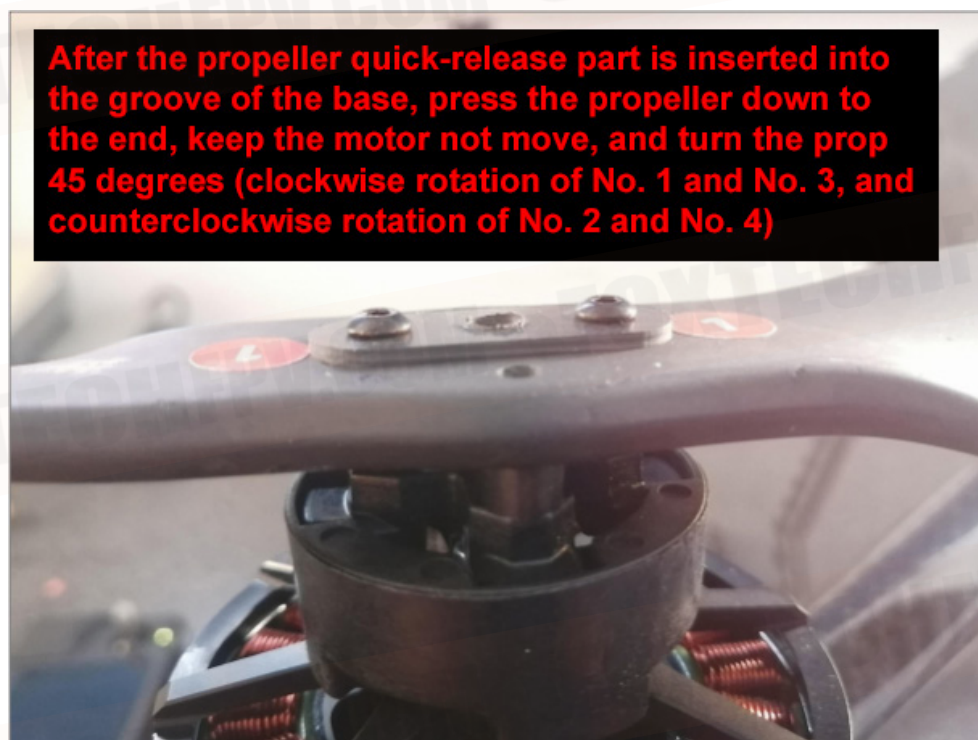
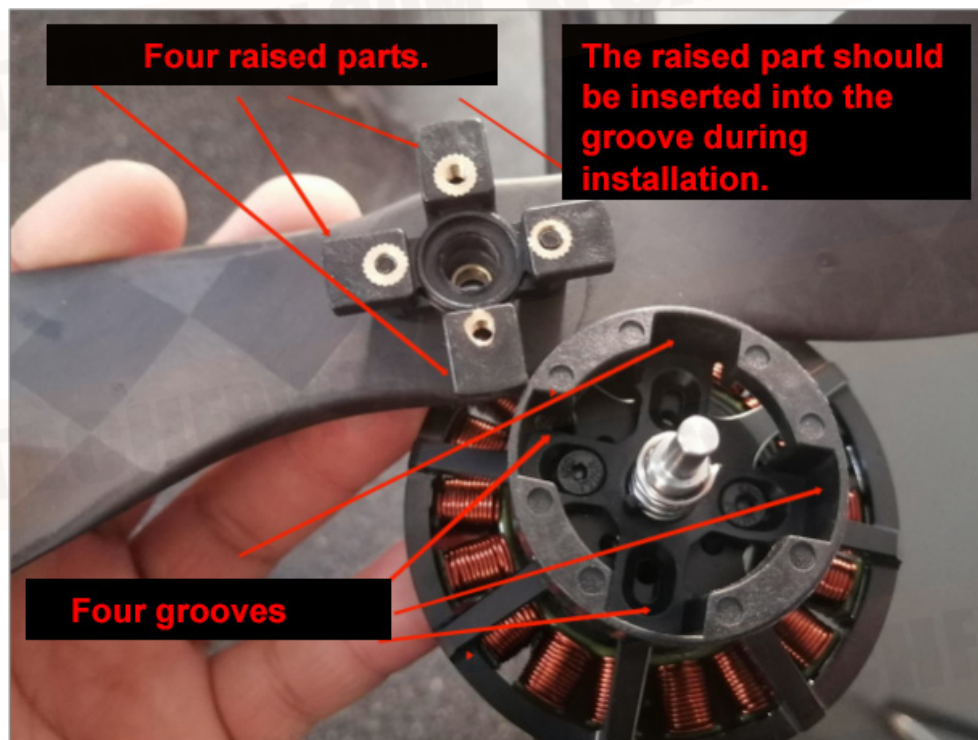

# MX16 Use Part

## Remote controller Diagram

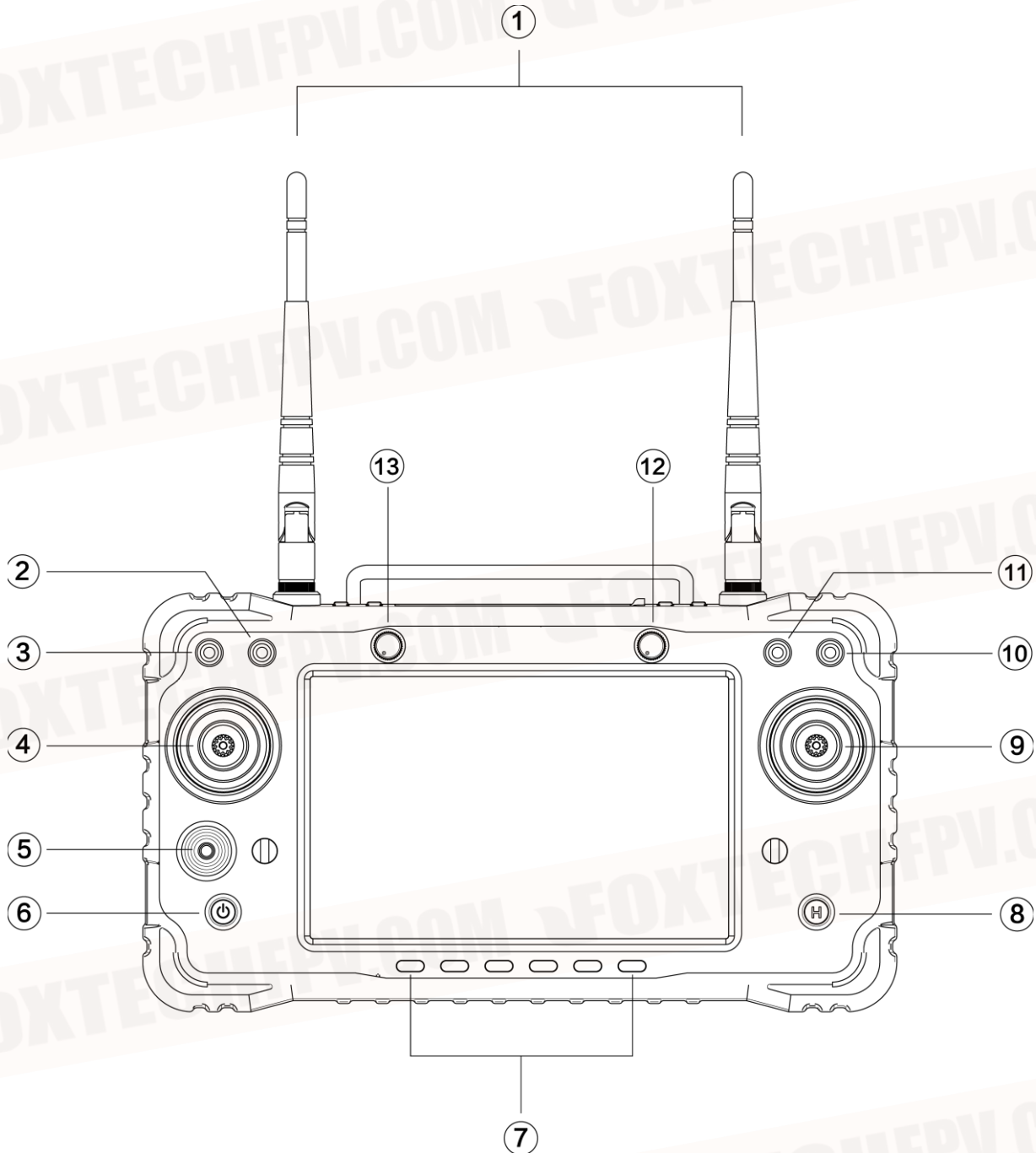

- |                          |                           |
|--------------------------|---------------------------|
| 1. 2.4G 3dB Antenna      | 8. button                 |
| 2. 3-position switch SW2 | 9. Right joystick X2. Y2  |
| 3. 3-position switch SW1 | 10. 3-position switch SW4 |
| 4. Left joystick X1. Y1  | 11. 3-position switch SW3 |
| 5. Small joystick X3. Y3 | 12. Dial AUX2             |
| 6. Power switch          | 13. Dial AUX1             |
| 7. 6-segment switch      |                           |

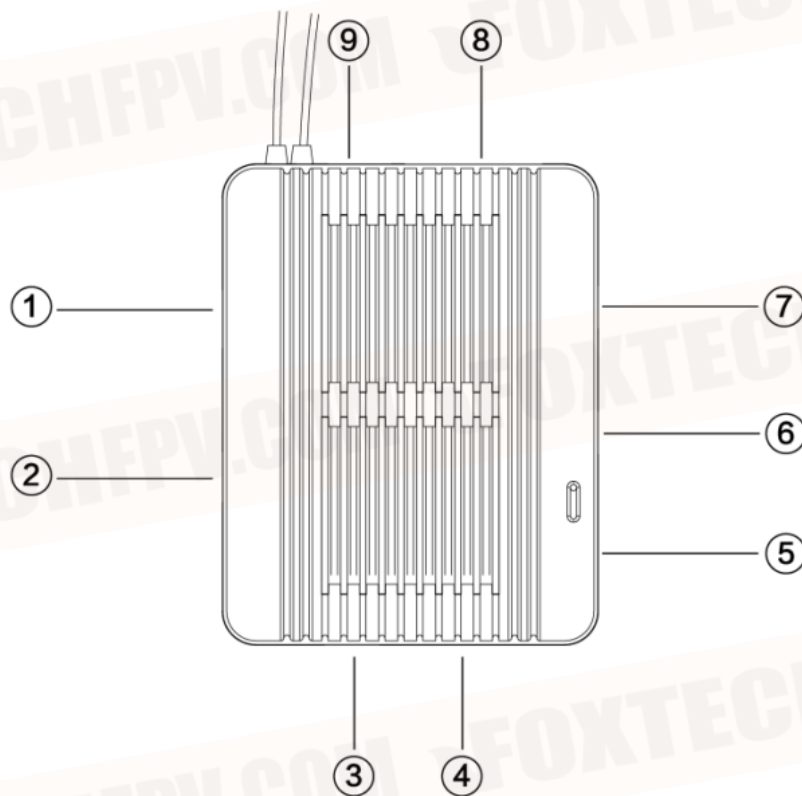
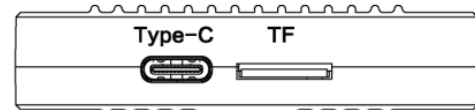
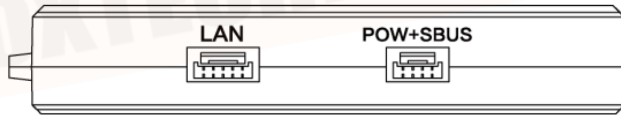
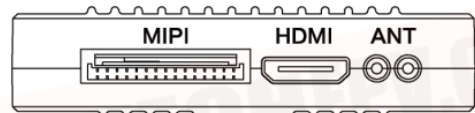

- |                            |                     |
|----------------------------|---------------------|
| 1. Ethernet Port           | 6. Serial port 0    |
| 2. Power and SBUS input    | 7. Serial port 1    |
| 3. Type-C port             | 8. MIPI camera port |
| 4. TF card port            | 9. HDMI input       |
| 5. Frequency paring button |                     |

Air Unit Interface

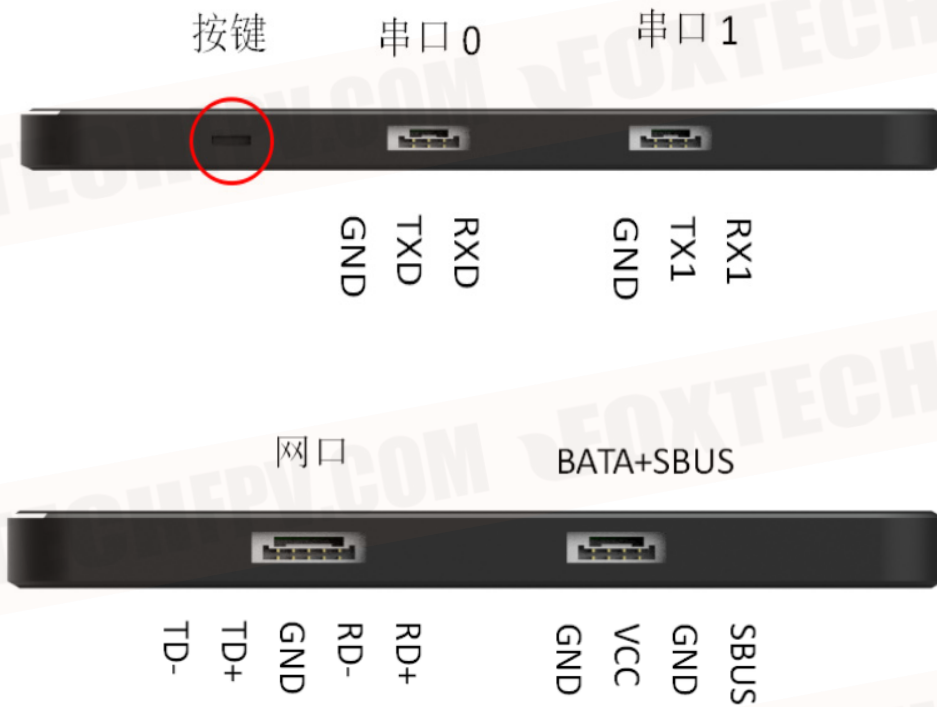

Status Prompt Bar



1. Access to internet successfully through Ethernet port or USB
2. Remote controller and receiver signal strength (the receiver is not connected in the picture)
3. Power
4. Time
5. Return
6. Back to the main surface
7. Background task management/split screen button

## MX16 Assistant



1. Switch the joystick control method of the remote controller
2. Check the channel value of the remote control.
3. Check MIPI HDMI UART VIDEO and other RTSP video.
4. Frequency pairing between remote controller and other receiver.
5. Can adjust the channel, upgrade the joystick firmware, modify the receiver serial baud rate. Ask the technician for the password.

## Frequency Pairing



1. Wait for 3s-5s after receiver is powered on, and then long press the SET button until the white light starts flashing.
2. Enter MX16 sddistant click frequency pairing, it will display 'connected' after the frequency successfully matched.

## Mode Changing

The mode of the product can be set according to customer requirements. If the customer needs to change the mode, please follow the steps below:

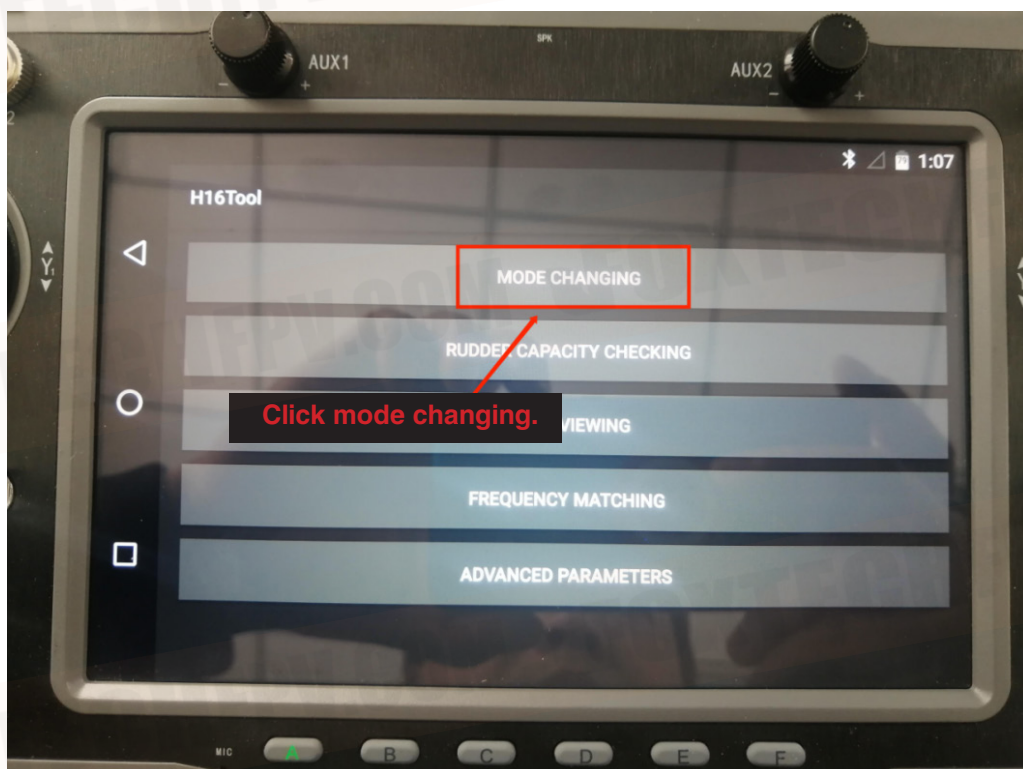





## Channel Reverse

If the channel is found to be reversed during use, you can change it according to the following steps:

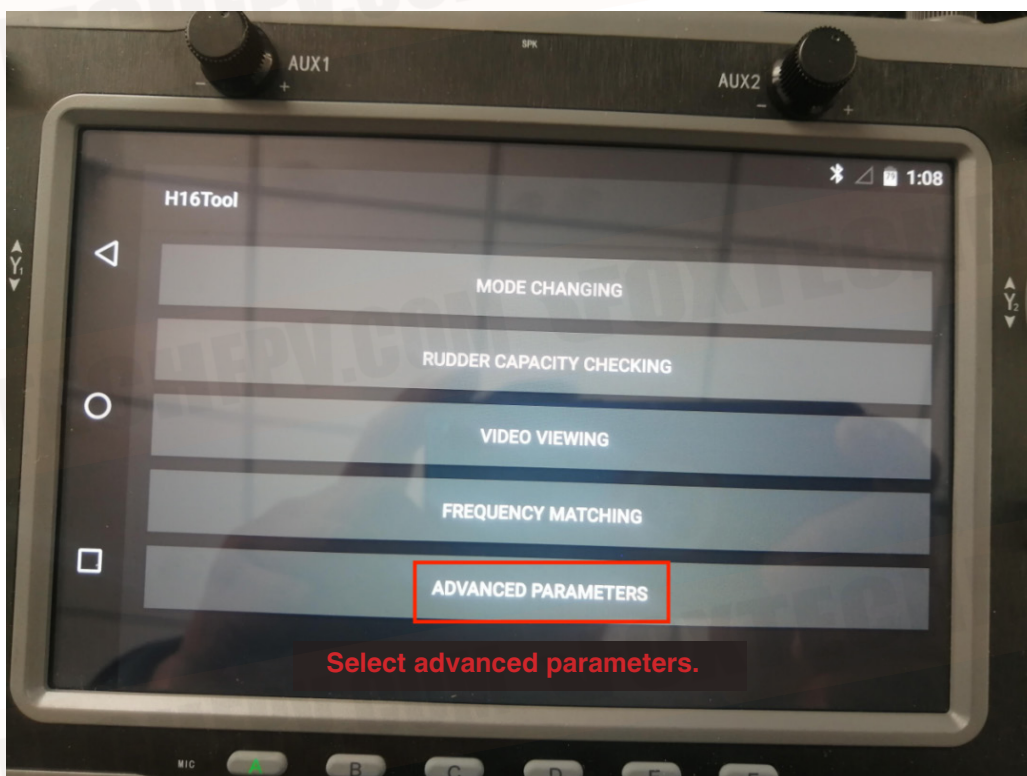

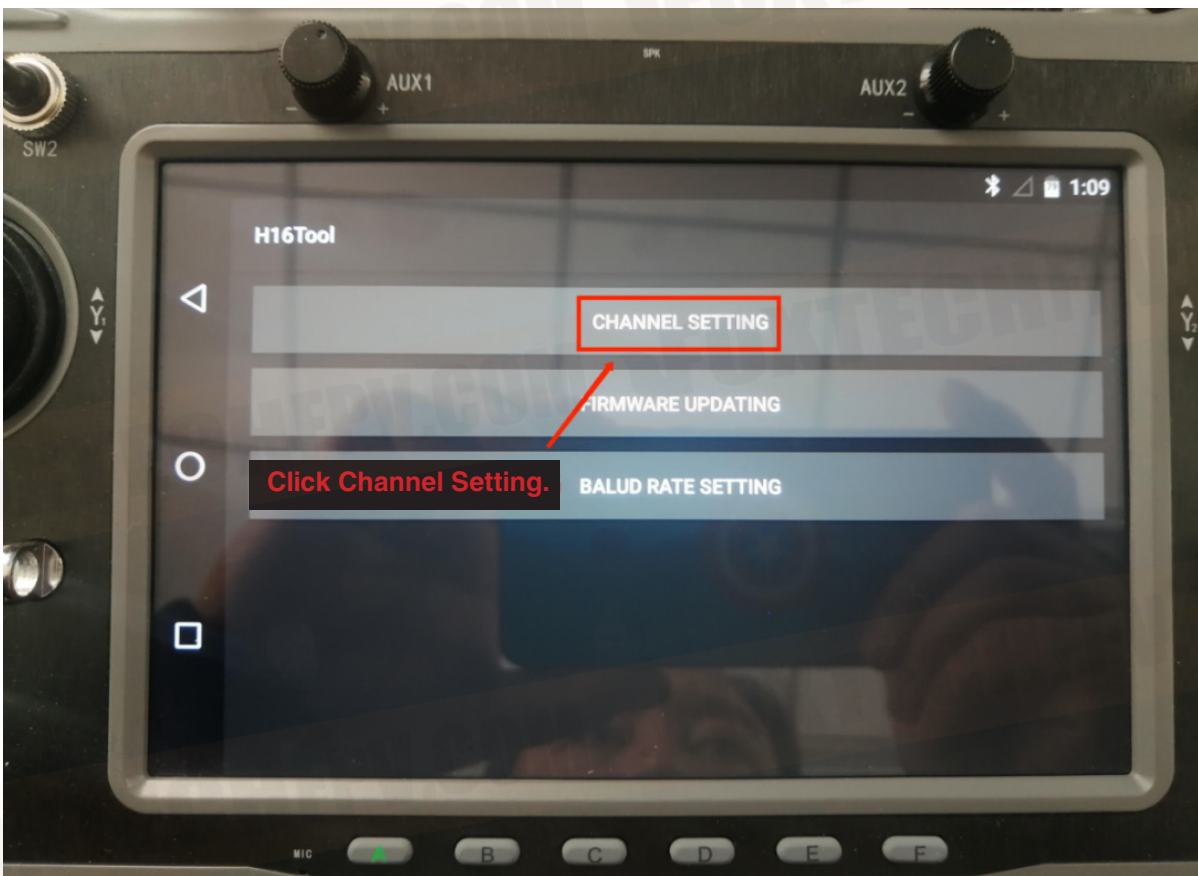
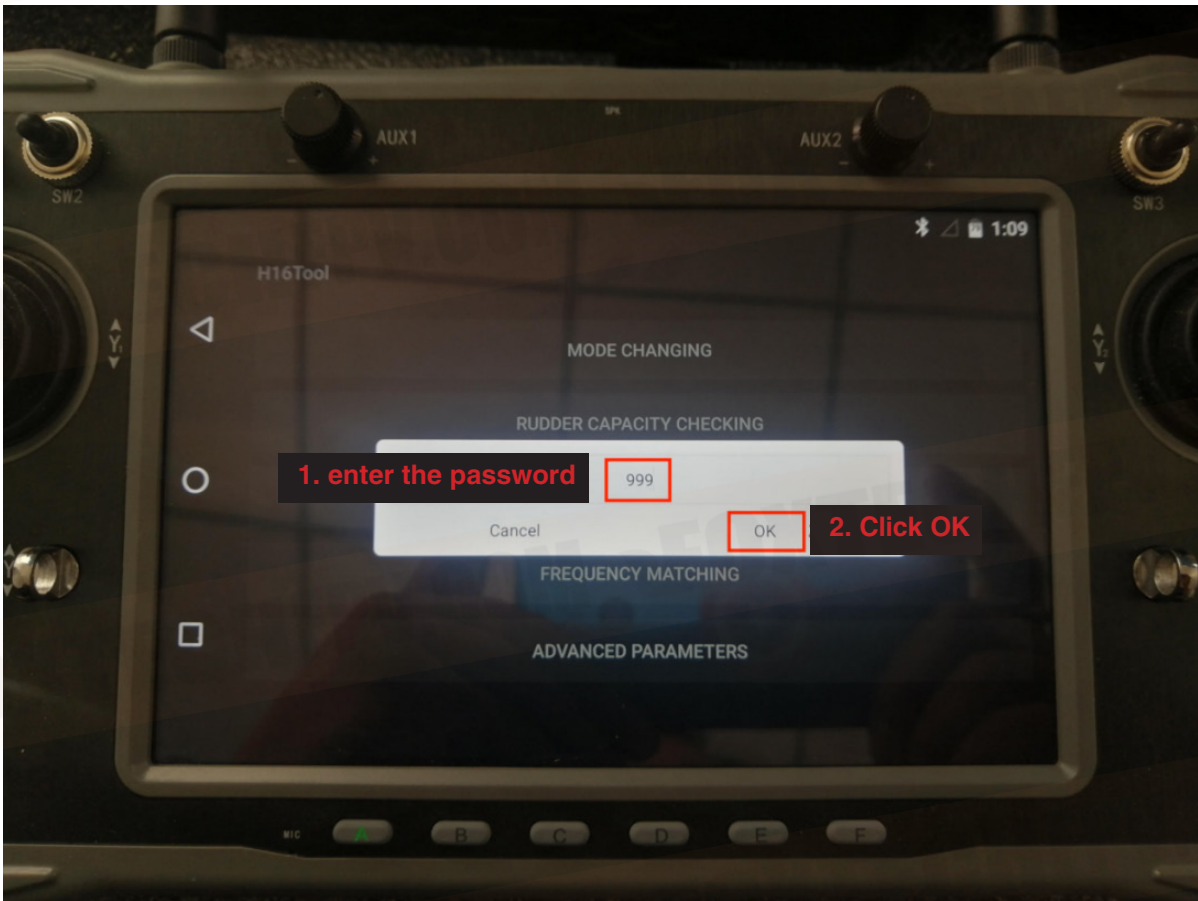

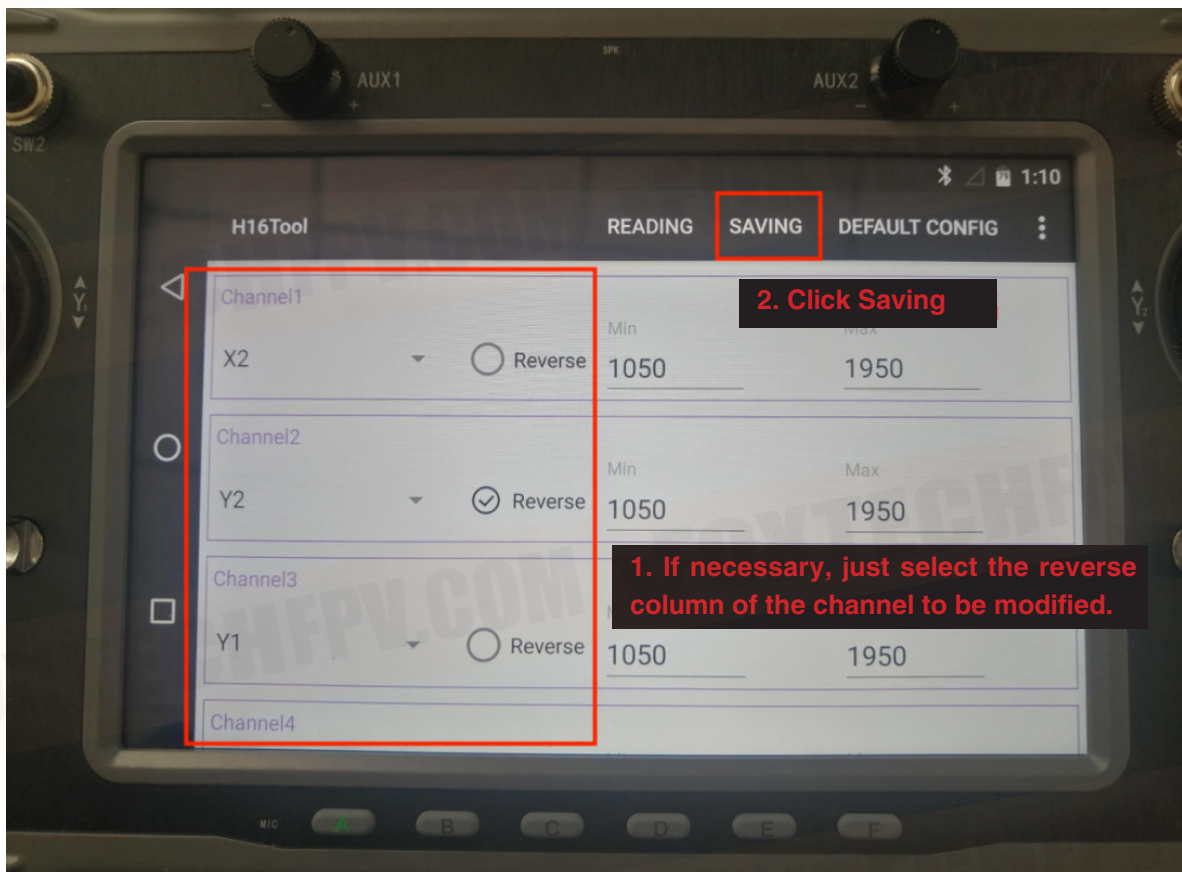

## Image connection and setting

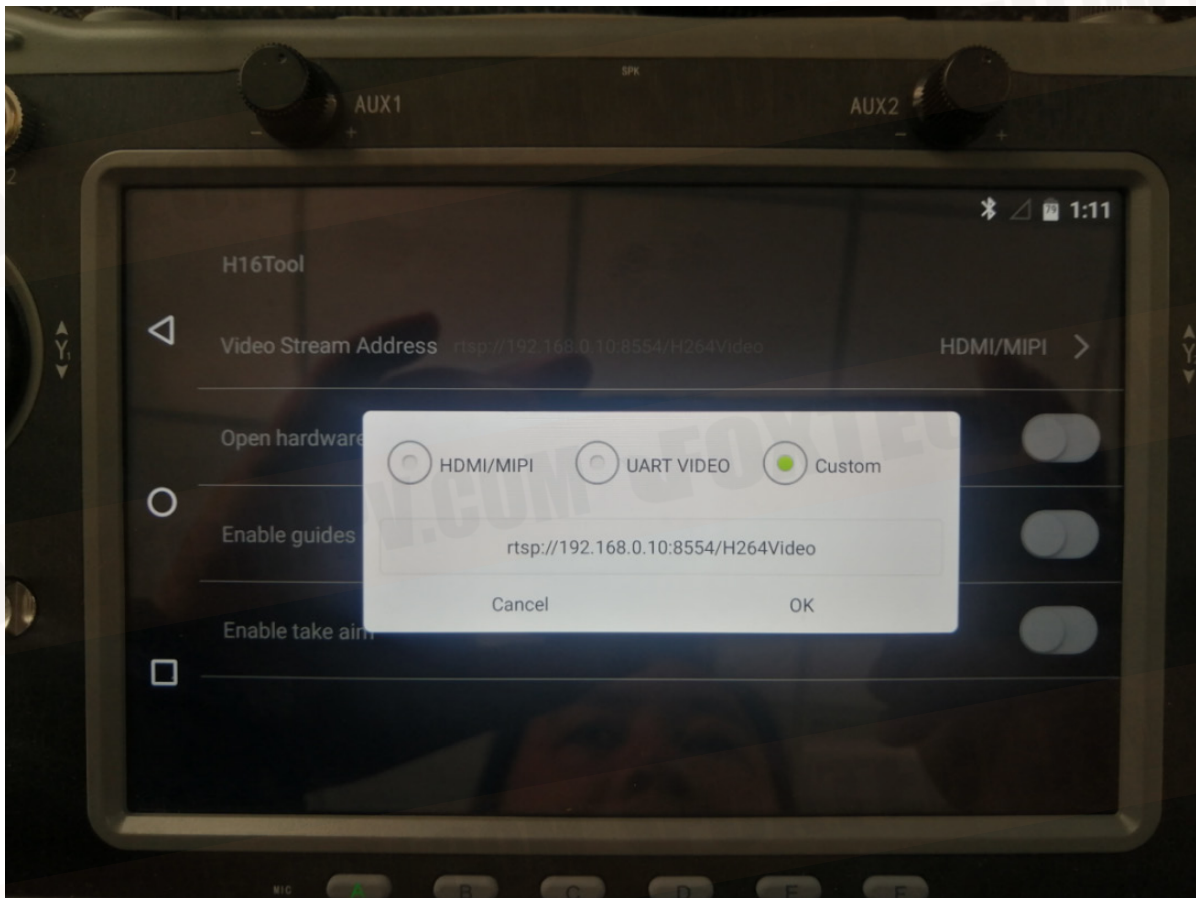

1. The factory default setting is HDMI/MIPI mode, which is used to display the image transmitted through the receiver.
2. UART VIDEO mode to display single-axis gimbal camera and MINI camera images (only applicable to 680 devices).
3. Custom mode, this mode is used to display the image transmitted through the network port of the air unit.

## Joystick Calibration



Click the rudder quantity checking in MX16 assistant, calibrate according to reference value.

- when the screen of the remote controller is completely turned off, center the knob. Long press the button C and D in the six-segment switch, then wake up the screen and slide the screen upward.
- release C D button and long press D. Start the calibration when the remote controller make a sound.
- Press D button to exit the calibration mode after reaching the max and minimum values of the left, right, small joystick and knob of the remote controller.

## Video Transmission Information Displayed on the Ground Station

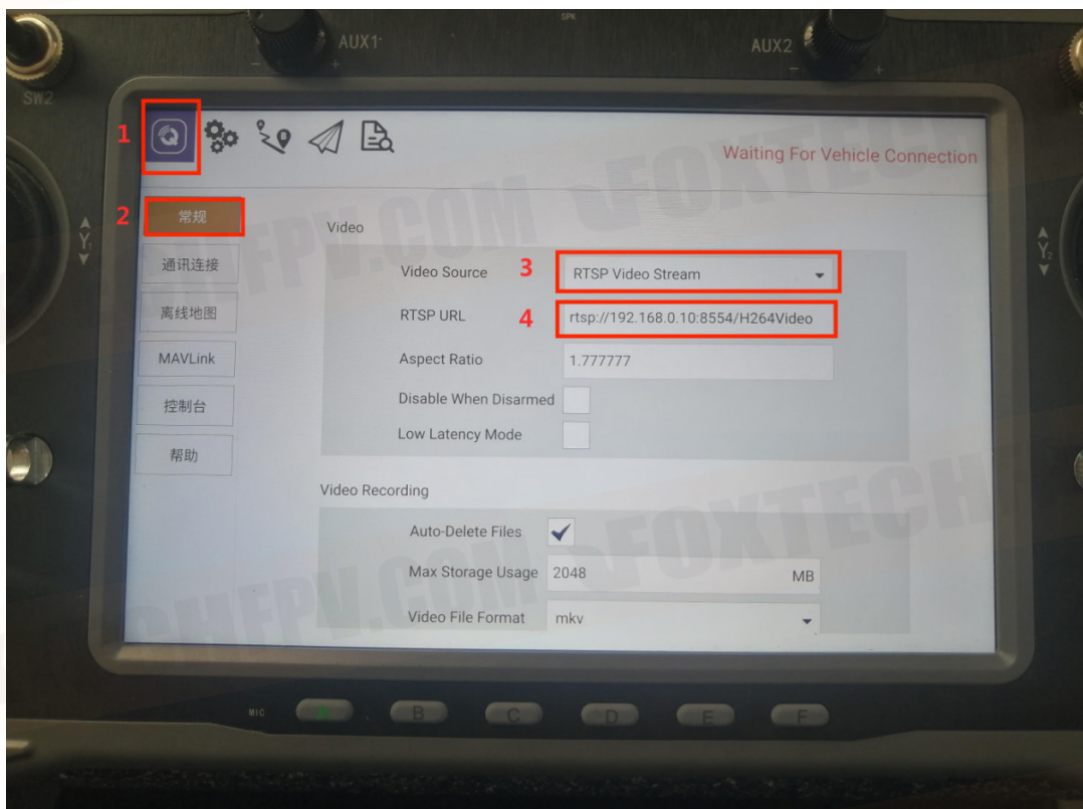

1. Click system setting icon in QGC
2. click 'General'
3. Change the video source to RTSP Video Stream
4. enter the video RTSP address in RTSP URL



Display MIPI HDMI image enter `rtsp://192.168.0.10:8554/H264Vide` in RTSP URL.

## Connect FC and Datalink in QGC

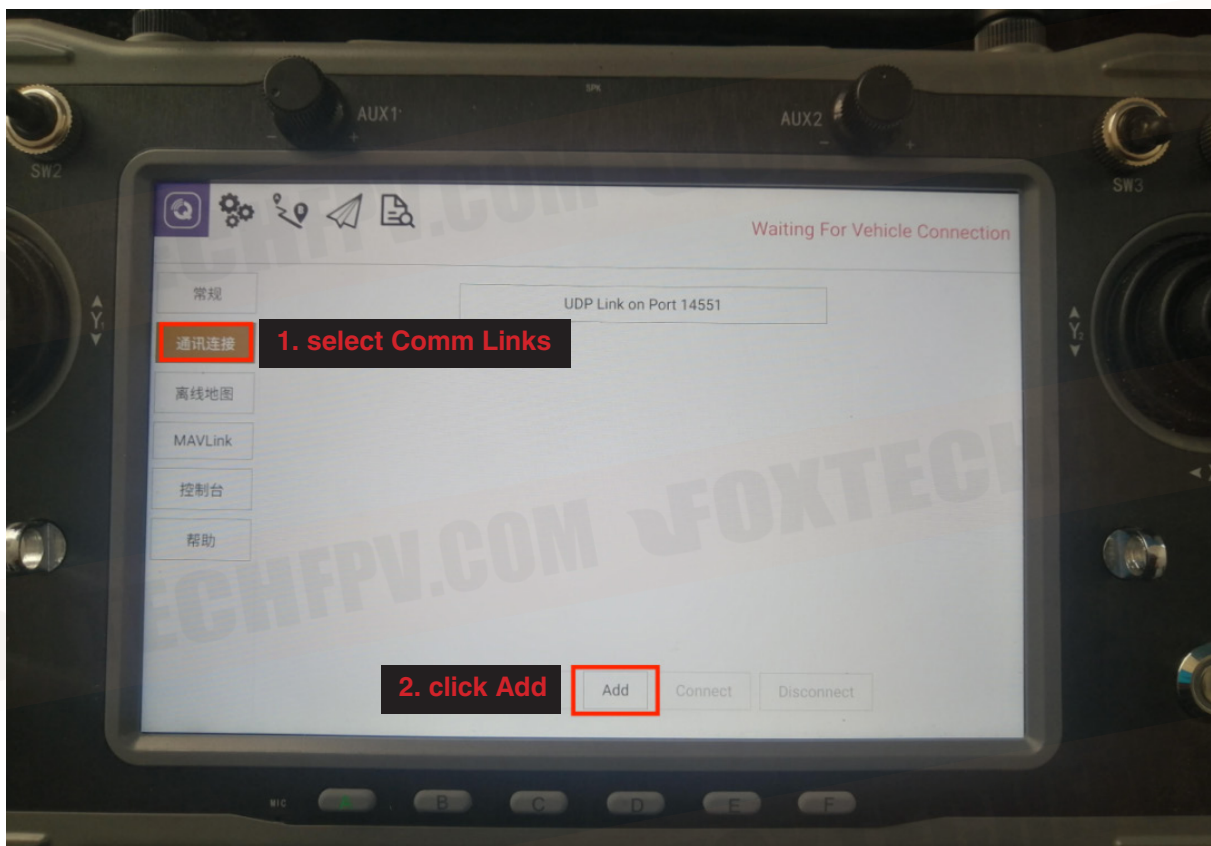

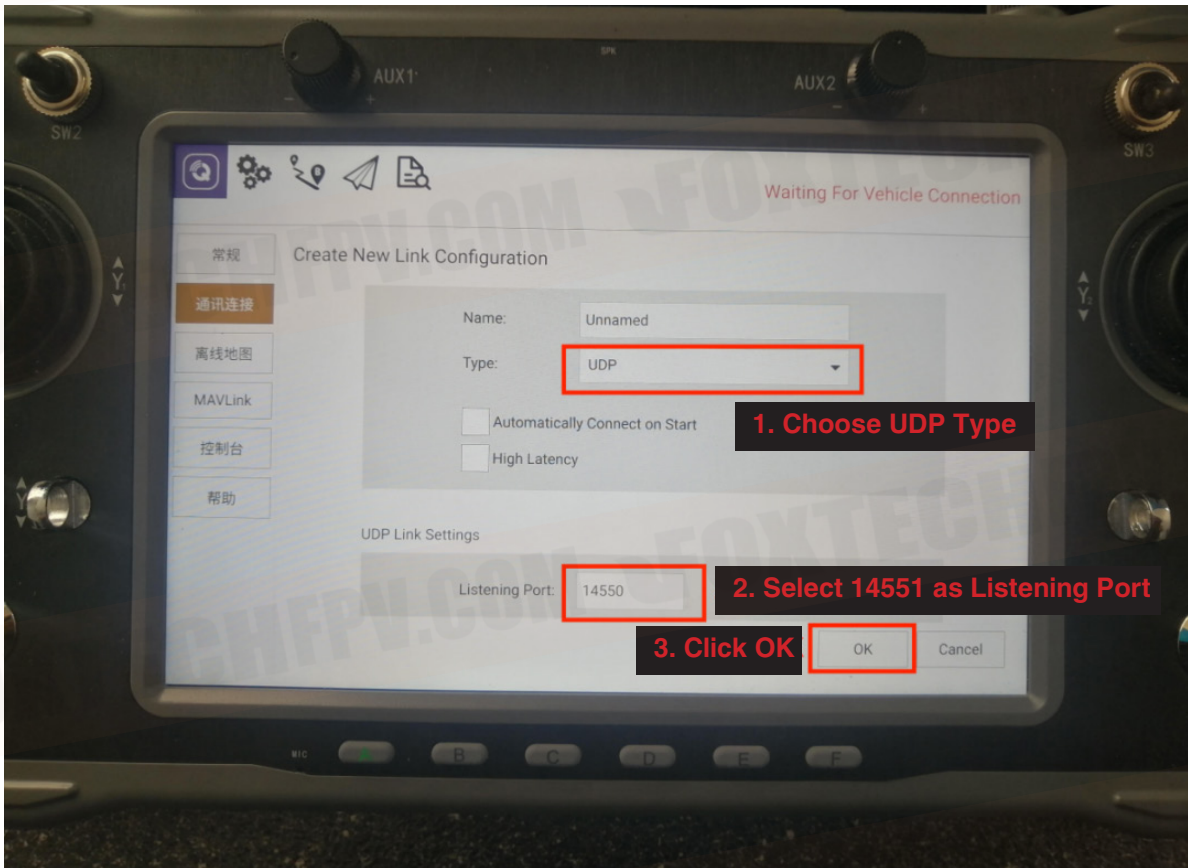

## How to share network, video and data information.

### - Share the internet

When the remote controller is connected to the internet via the USB wireless card, the hot spot of the remote controller can be turned on for network sharing.

### - Share the Data link

1. open the hot spot of the remote controller
2. connect the computer to the remote controller's hot spot.
3. Open Mission Planner, choose the UDP connection method.



4. After clicking connect, select 14550 for the port number, then click OK.

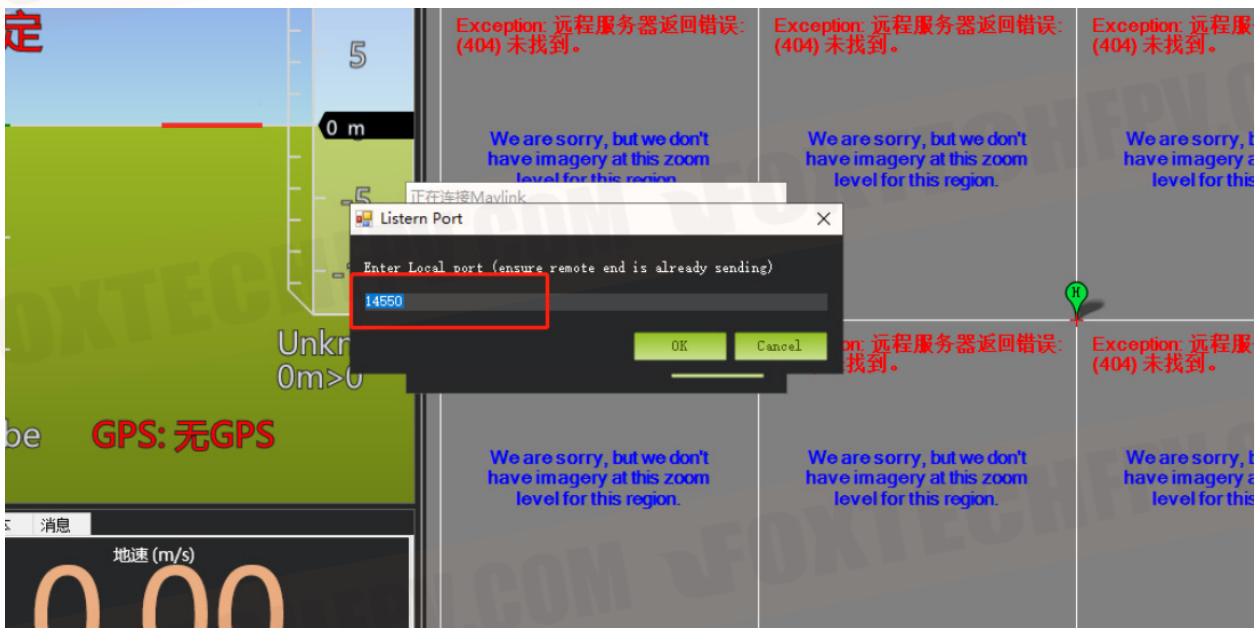



## - Video link Sharing

1. open the hot spot of the remote controller.
2. connect the computer to the remote controller's hot spot.
3. open the computer's settings, click on the adapter, select Ethernet, select the IPV4 protocol,select a custom IP address, enter as shown in the figure, then click 'confirm'.

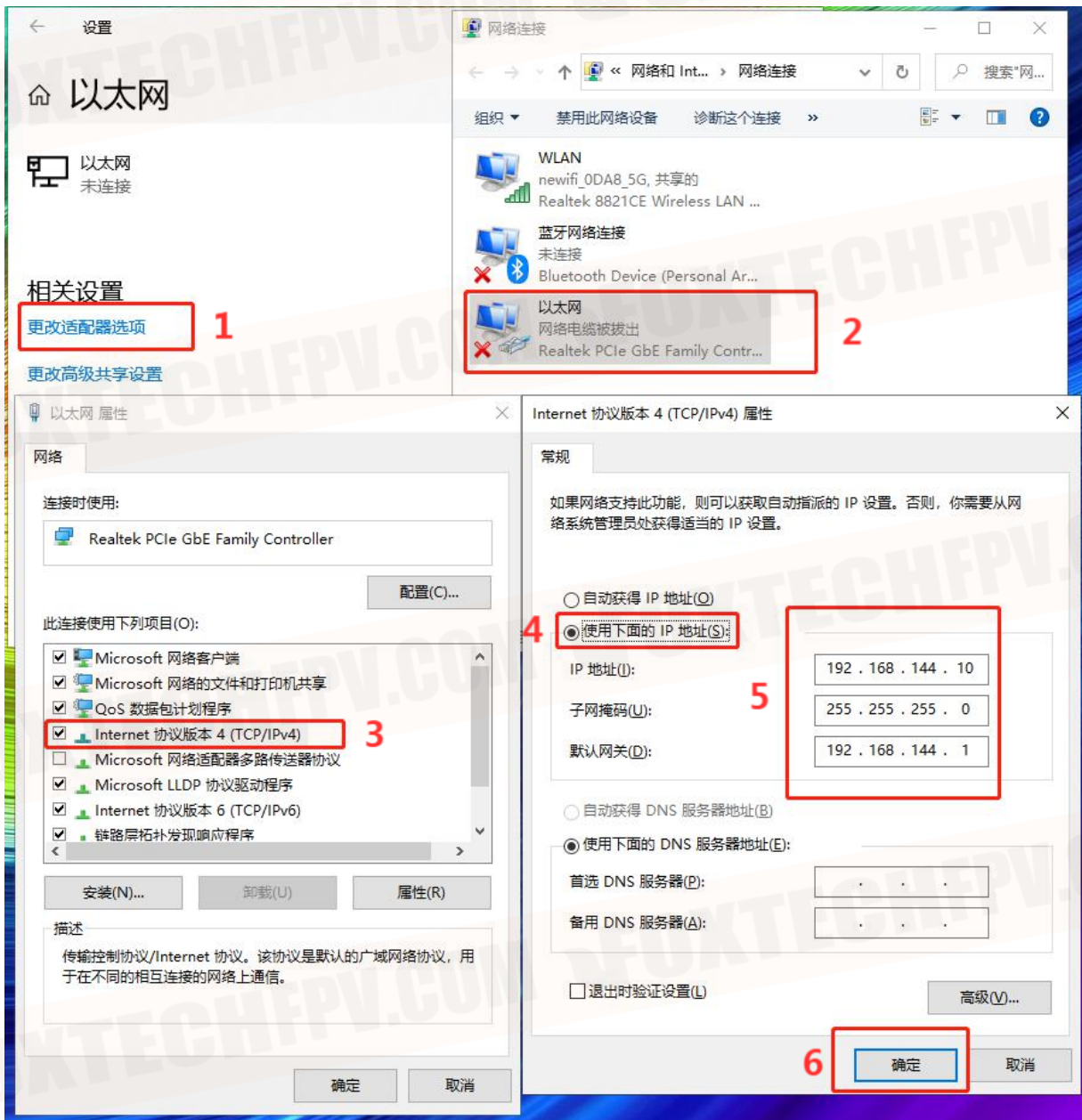

4. Download VLC  software to display the video.

5. Open the VLC software, select Network streaming in the media.
6. In the input field of the network URL enter `rtsp://192.168.43.1:8554/fpv_stream` and click play.

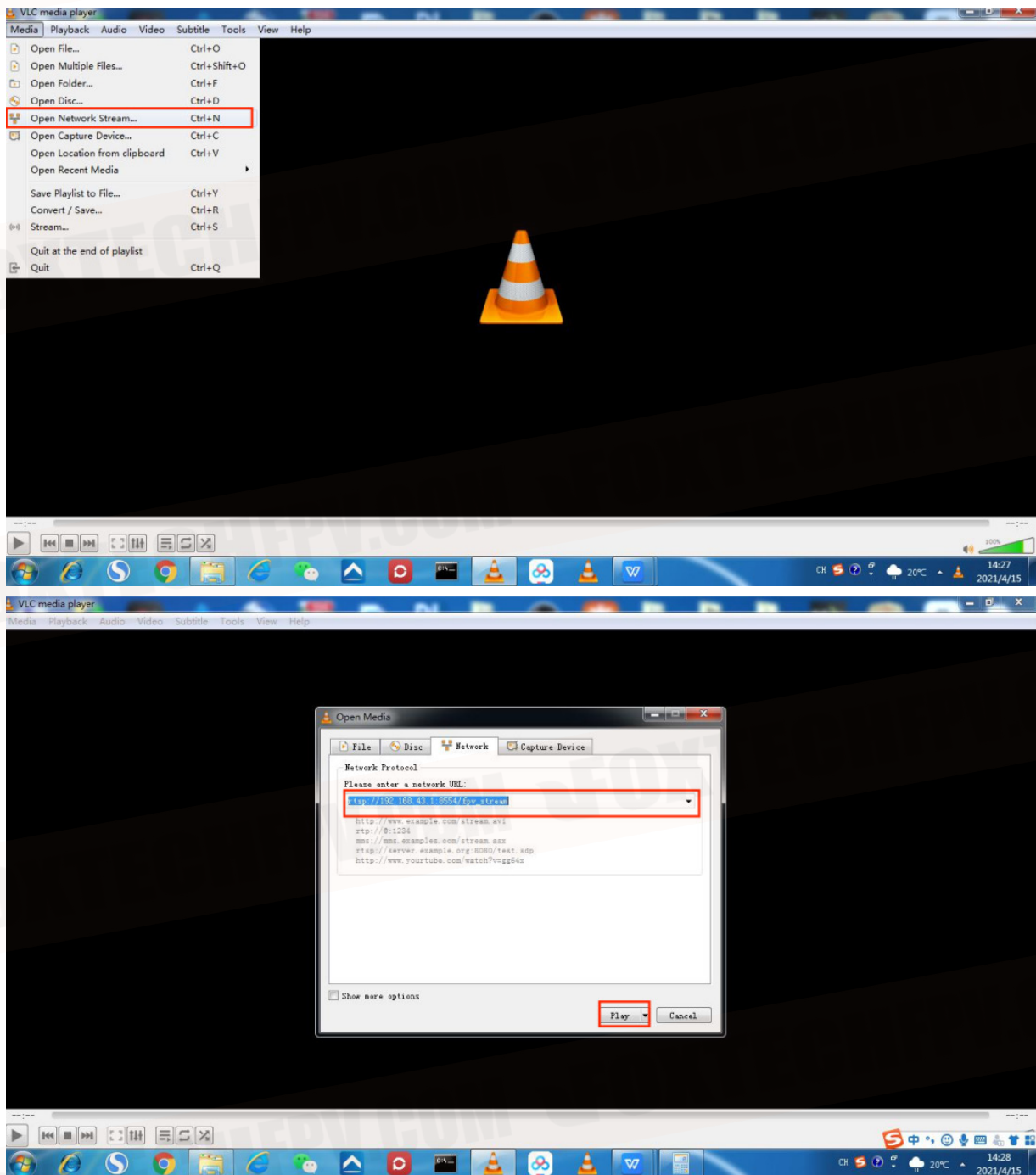

# Mission Planner Basic Operation

## Download and Install Mission Planner

Before installing the firmware for The Cube, please download the stable version of Mission Planner from the ArduPilot website. Mission Planner currently supports Windows, just download the corresponding version according to your needs. Take the Windows 10 system as an example. Download the installation package with the extension .msi on the official website. After the download is complete, right-click to manage Run the installer as an administrator. During the installation process, the device driver will be installed. If prompted, click Yes to confirm the operation.

Software download website: <http://firmware.ardupilot.org/Tools/MissionPlanner/>

## Connect with The Cube

Connecting The Cube usually has two connection methods: wireless data transmission and USB. Mission Planner also supports Bluetooth and IP address connections. No matter what kind of connection you use, your data transmission driver or serial port driver must be installed correctly to ensure the normal operation of the data link, then the Cube can be connected to the ground station.

Use USB connection: Insert the USB into the USB port on the left side of The Cube, and try not to use a USB hub when connecting to the computer. In the device list in the upper right corner of Mission Planner, click the arrow in the drop-down box, select the COM port corresponding to the device, and set the baud rate to 115200 on the right.

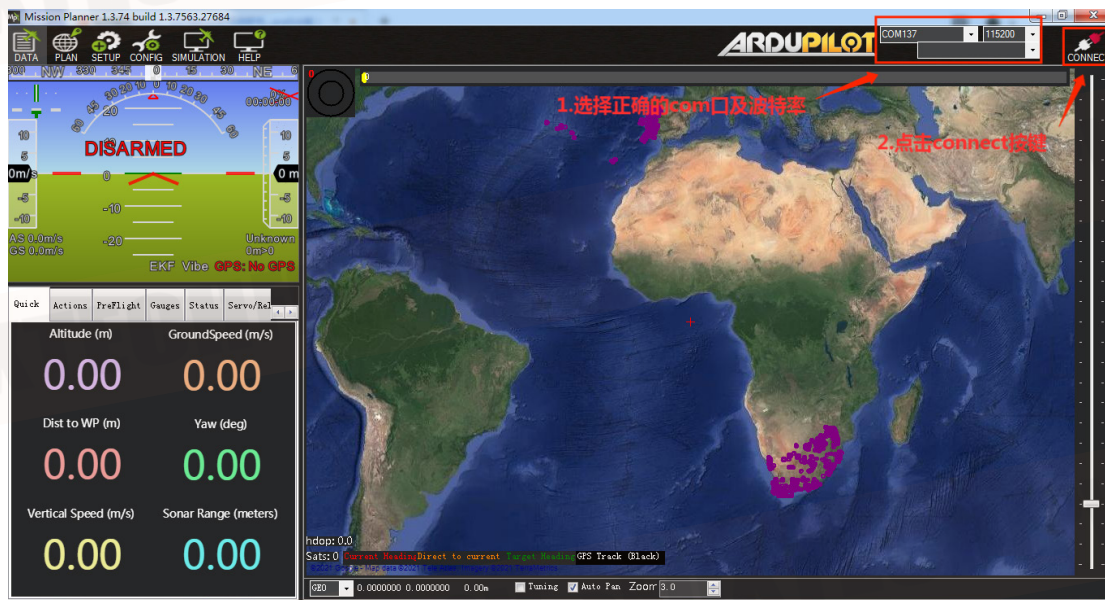

Data transmission connection method: usually use USB to connect the data link of the ground station you need to select the corresponding COM port, and set the baud rate on the right side to 57600; while if using WIFI or Bluetooth to connect the data link of the ground station, it is in the device list Select the corresponding type and fill in the IP address to connect. For specific parameters, please refer to your data link instructions first.

## Connect with The Cube

Before installing the firmware, select the corresponding device and baud rate (the same configuration as when connecting the device), and keep the link in the upper right corner of the Mission Planner disconnected. Enter the installation firmware interface of the initial settings, select your vehicle type and click, and follow the prompts to install.



After connecting, install the firmware under boot. When the information indicator bar shows that the download is complete, plug the USB and connect again.

If you hear the prompt beep, it means that your firmware has been successfully installed. If you hear 3 continuous beeps, unplug and reconnect the USB and press the safety button. After restarting, when you hear two consecutive beeps, it means that your firmware has been downloaded successfully.

## Basic Hardware Calibration and Parameter Setting

### 1. Frame type setting

Open the Mission Planner ground station, connect to the flight controller, select the frame type in the necessary hardware in the initial settings, and select the corresponding frame such as a cross-shaped X-shaped frame.

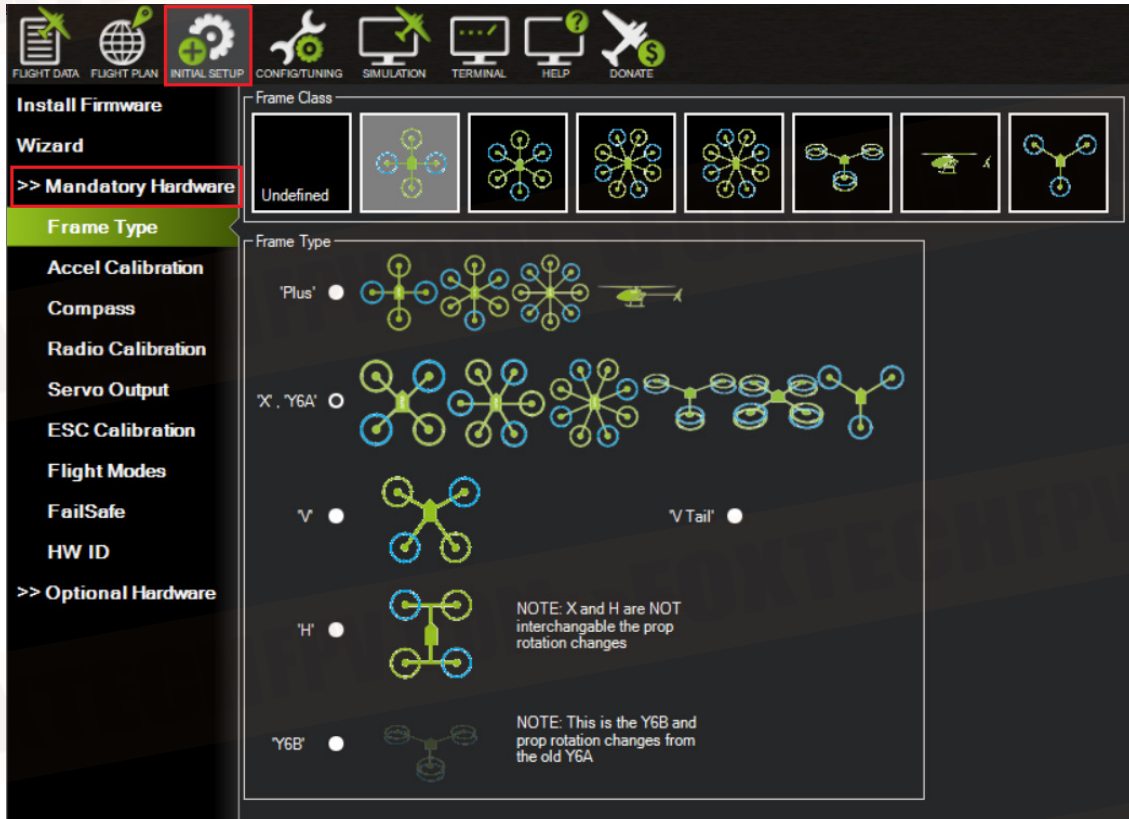

### 2. Accelerometer and compass calibration

Select the accelerometer calibration, follow the instructions of the ground station, orient the aircraft nose according to the six directions of LEVEL RIGHT, NOSEDOWN, NOSEUP and BACK to calibrate. If the calibration is successful, it will prompt successful.

#### Accelerometer calibration

Place the aircraft horizontally and press any button to continue

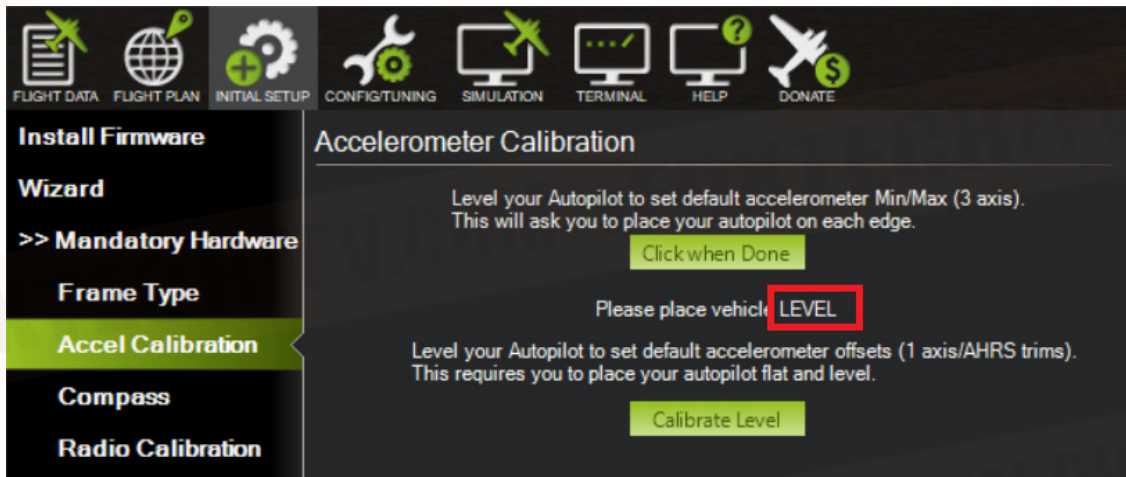

Place the aircraft's nose facing forward, left, and down vertically, and then press any button to continue.

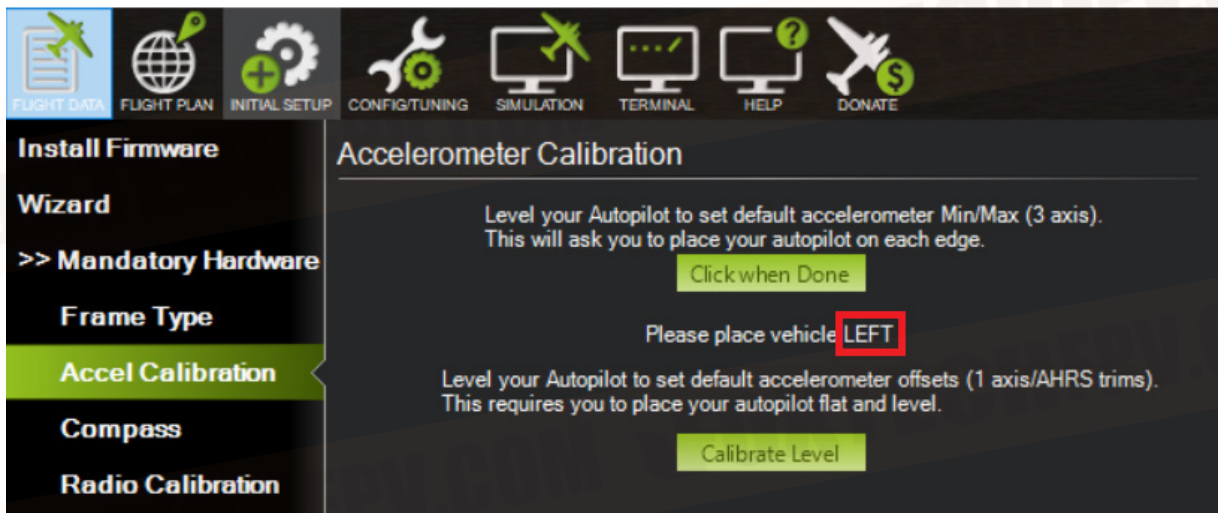

Place the aircraft's nose facing forward, right, and down vertically, and then press any button to continue.

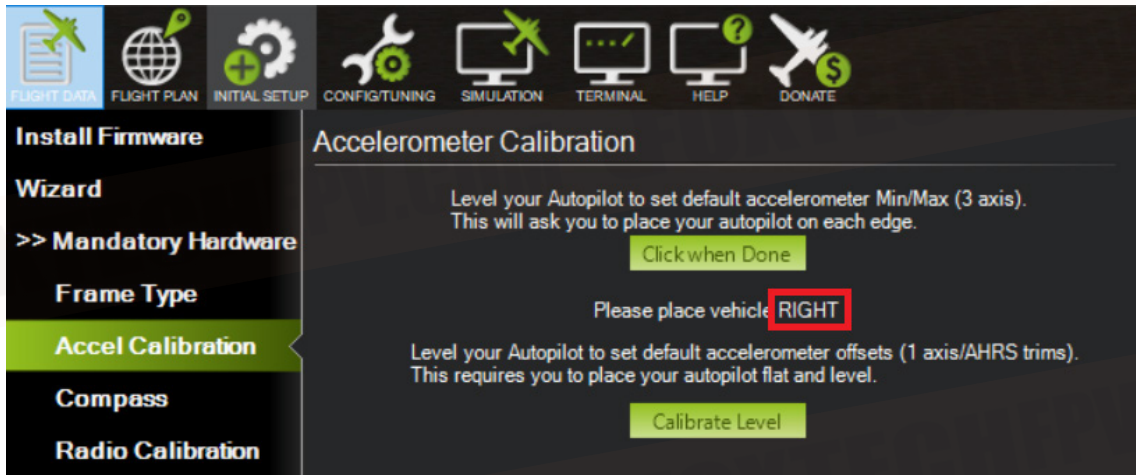

Place the aircraft nose down and place the aircraft vertically then press any button to continue.

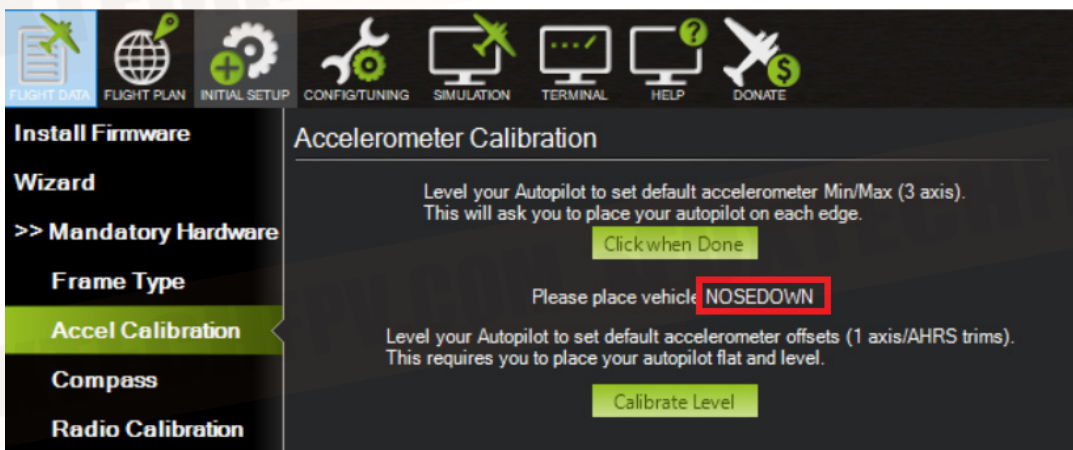

Place the aircraft with the nose up and vertically then press any button to continue.



Place the aircraft horizontally with the bottom up

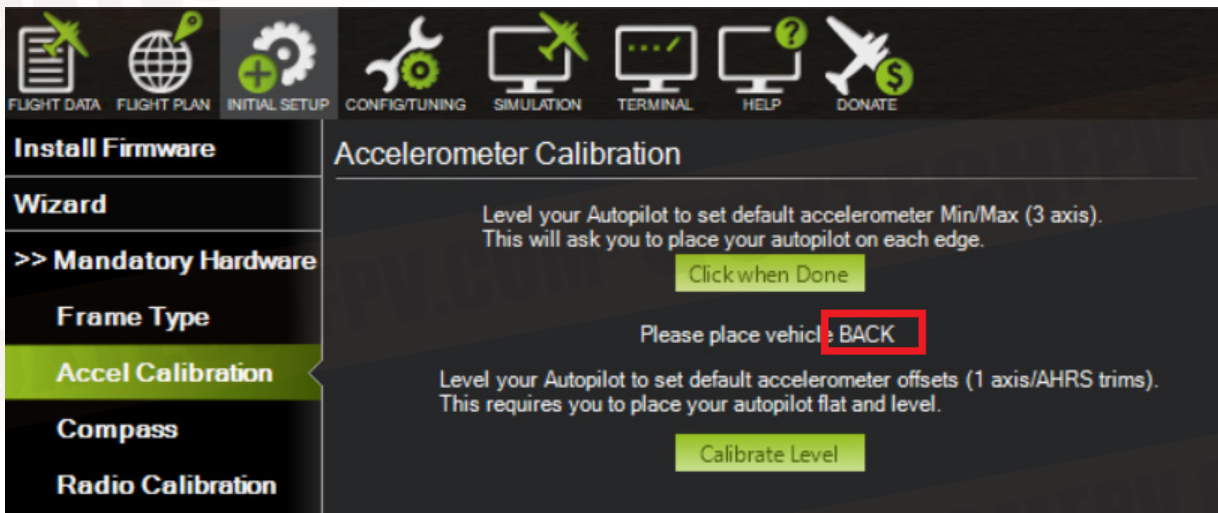



After the calibration is successful, it will prompt Calibration successful.

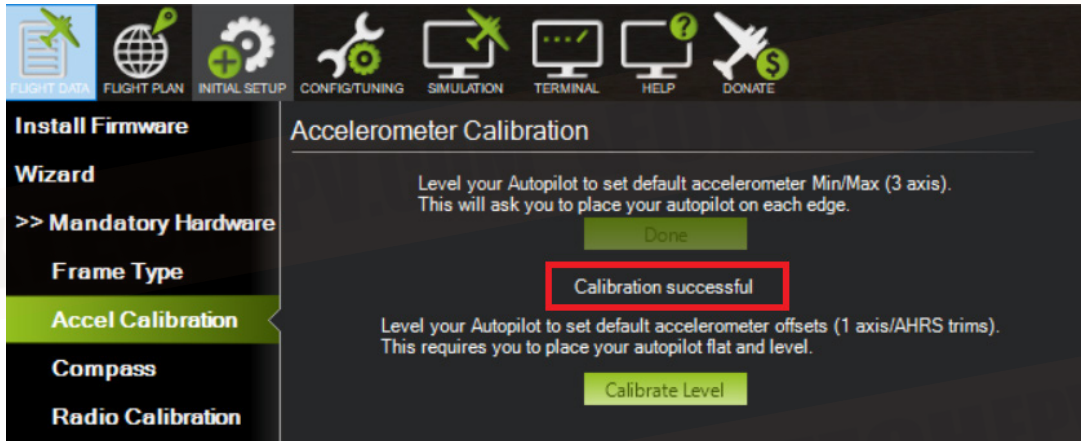

### Horizontal calibration

Place the aircraft horizontally, click on the level calibration and it will appear complete to indicate that the calibration is complete



### Compass Calibration

Select the initial setting—necessary hardware—HWID, check the ID number of the CAN port compass, and then select the compass, select to enable the Use compass ID number according to the ID number of the CAN port compass, and adjust the use priority of the CAN port compass to the best. Click to start calibration. Please rotate the flight control within 60 seconds. Each axis should rotate at least once: pitch 360 degrees once, roll 360 degrees once, horizontally and in situ rotation 360 degrees once, and each face rotates 360 degrees at least once.

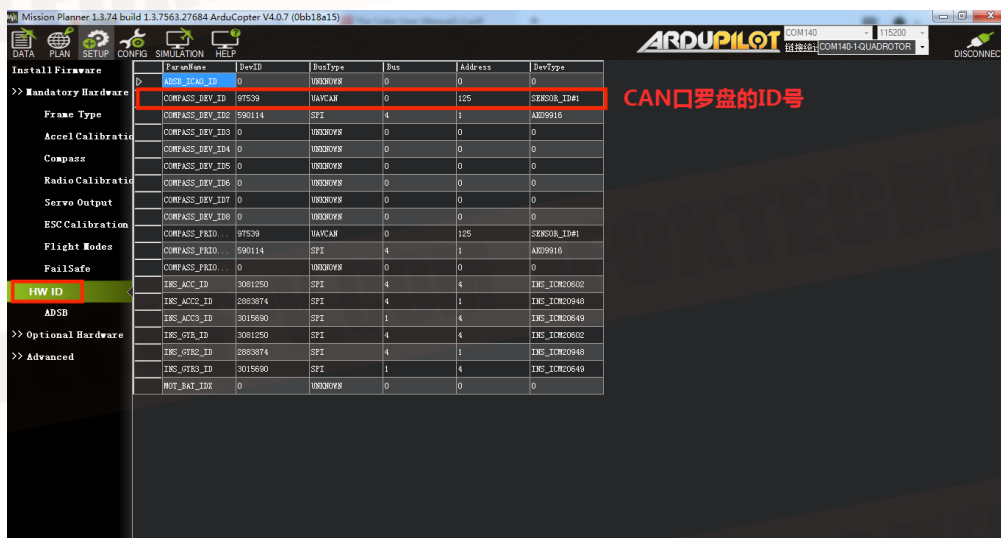



If the calibration is success,the window will show success, and the compass will show success.

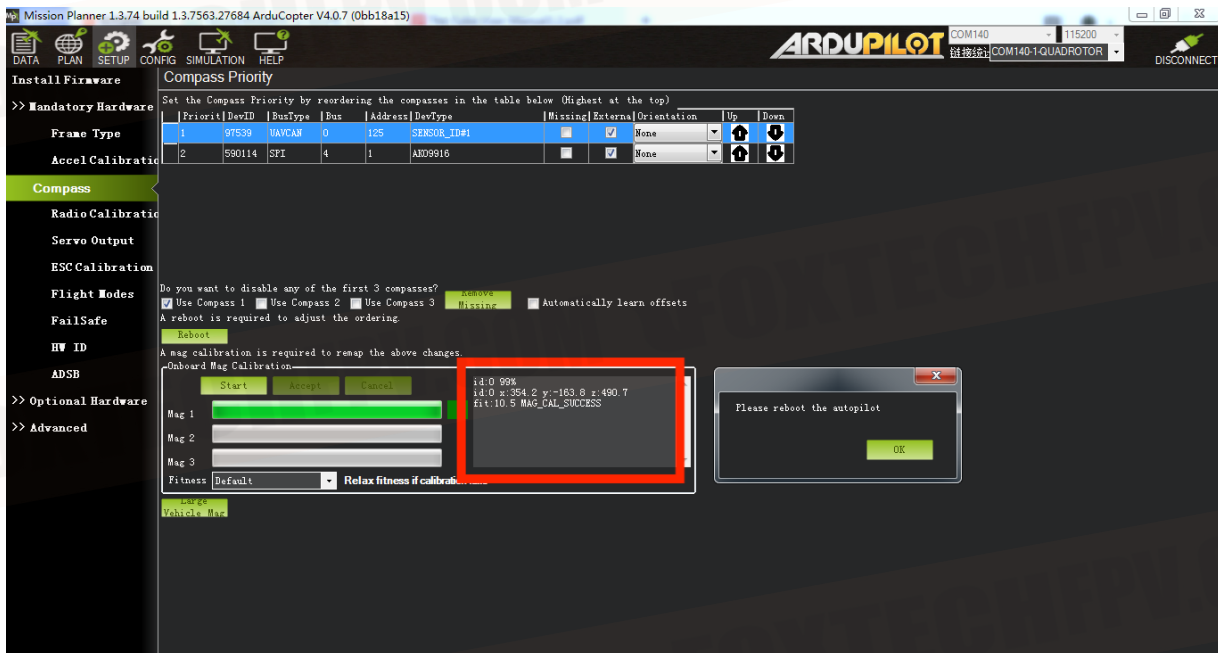

After calibration, you will be prompted to restart the autopilot, click OK, unplug and reconnect the USB.

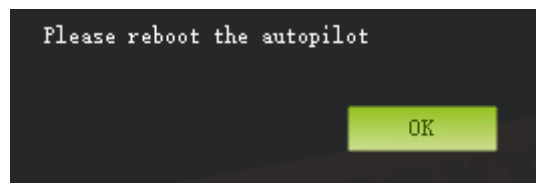

If the calibration fails, you can set Fitness. Normally, select Default.

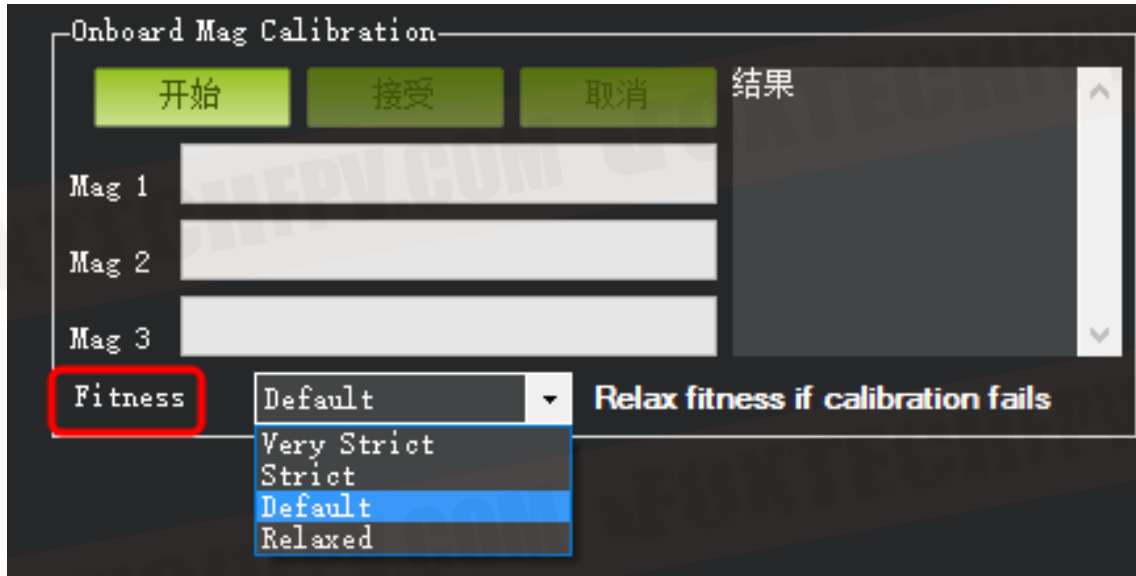

### Remote controller calibration

Remote calibration requires the flight control RCIN channel to be connected to the receiver. After connection, turn on the power of the RC transmitter. Then click the remote control calibration button in the lower right corner of the window, and toggle the remote control switch to move the red prompt bar of each channel to the upper and lower limit positions. After the red line calibration of all channels is completed, click the Finish button. If the indicator bar above does not change when you move the joystick, please check whether the receiver is connected correctly, and also check whether each channel corresponds to it at the same time.





### ESC calibration

Safety checking: Before calibrating the ESC, please make sure that there is no propeller mounted on the plane.

Connect the aircraft to the MP ground station through data link, select configuration and debugging—all parameter list—search for the "esc" keyword, change the ESC-CALIBRATION parameter value to 3, click Write parameters, and power off the aircraft again. Wait for the flight controller to automatically complete the ESC calibration procedure. After the calibration is completed, power off the aircraft and restart it.



### Flight mode selection

Set the 5 channel or the other channel on the remote control (which can be set by all parameters FLTMODE-CH) to the appropriate position, Mission Planner will display the current position in green, select a mode for each switch and click the save mode button. The remote controller can set up to 6 flight modes, and you can set up 6 single-channel mixing according to your own remote controller instructions.

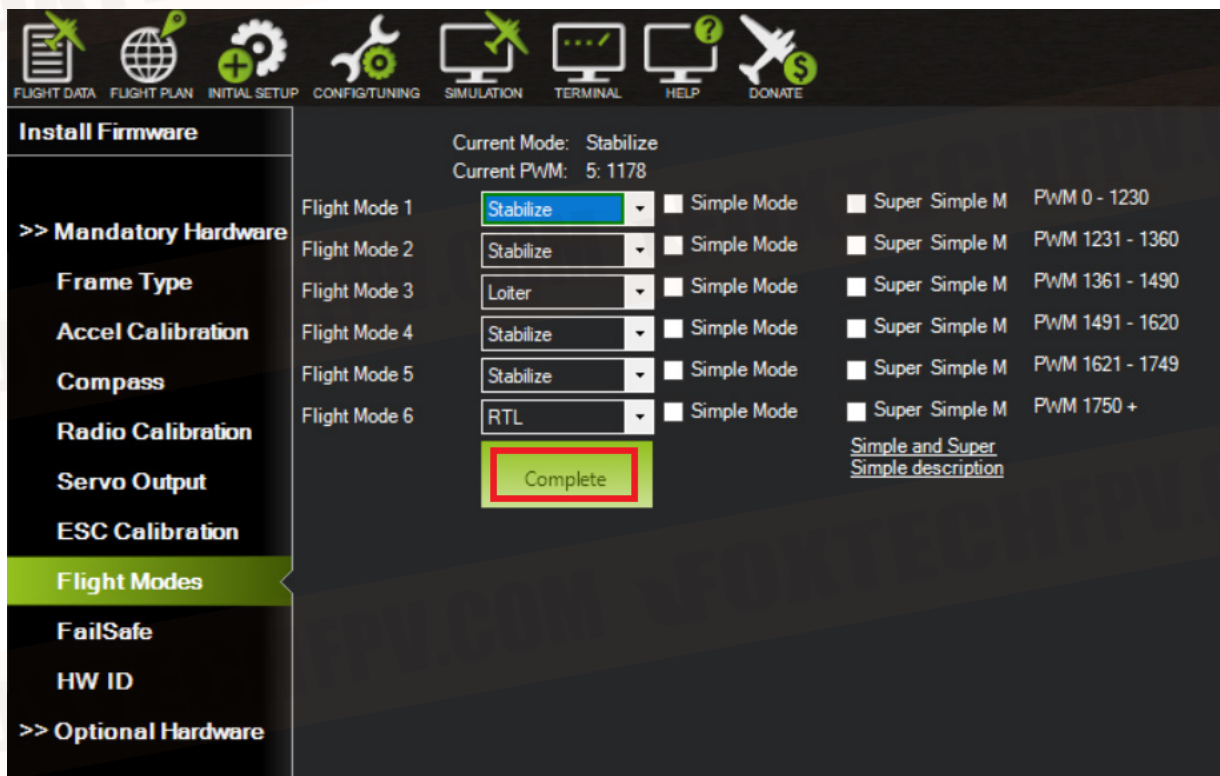
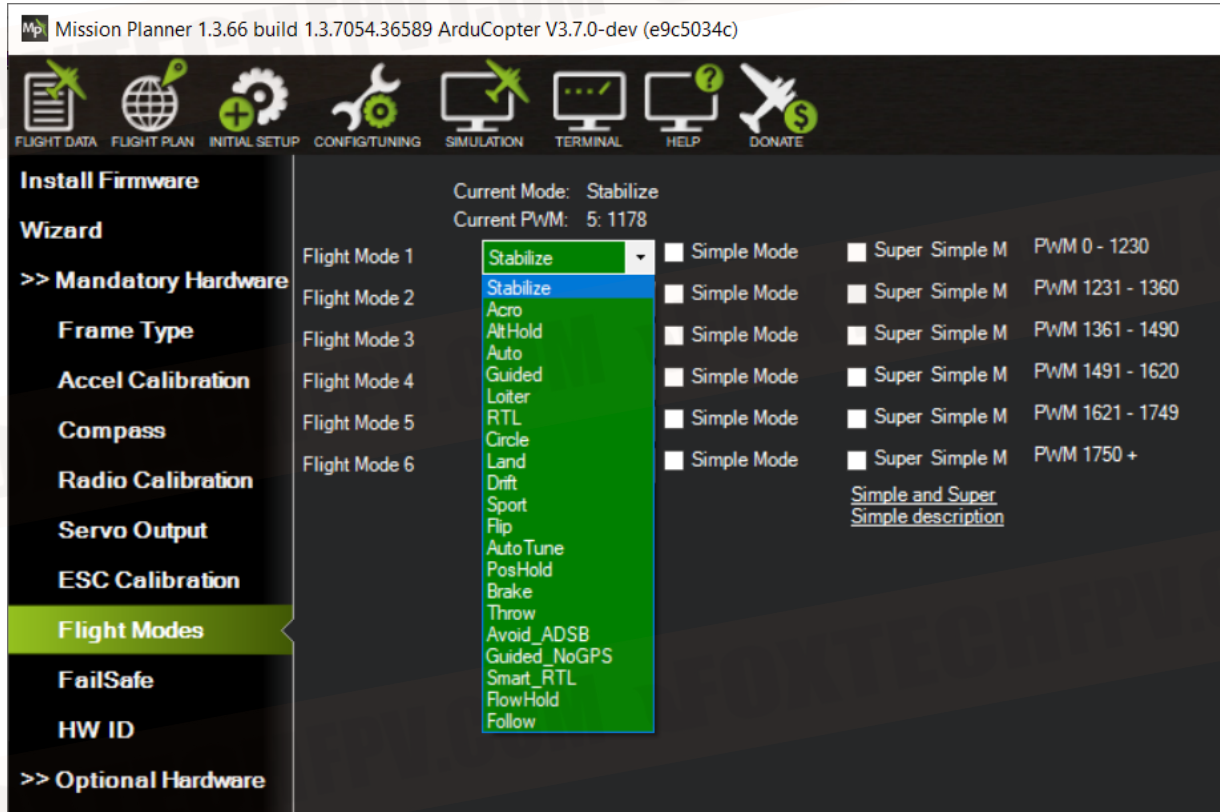

#### Four commonly used flight modes:

##### - ALT HOLD

After the first test flight, you can try the altitude hold mode. This mode does not require GPS support. The autopilot will maintain the current altitude based on the data from the air pressure sensor. If the point is not fixed during altitude hold process, the aircraft will still drift. Can be remotely controlled to move or maintain the position. When setting the altitude, the autopilot controls the throttle to maintain the altitude. But you can still use the remote controller to control throttle to adjust the height, not for landing because the throttle will not drop to zero.

When switching between stabilized mode and altitude hold mode, keep the throttle of the remote control transmitter at the same position to avoid sudden rise or fall of the aircraft due to mode switching and changes in throttle control mode.

##### - Loiter Mode

The loiter mode is the GPS fixed-point mode. You should let GPS fix the point before taking off to avoid sudden positioning problems in the air. Other aspects are basically the same as the altitude hold mode.

##### - Auto mode

In this mode, the aircraft will automatically perform tasks set by the Mission Planner on the ground station, such as taking off and flying to multiple waypoints in sequence, rotating, and taking pictures.

##### - RTL

GPS positioning is required for the return home mode. The GPS positioning point before ARM is the current "home" position; if GPS is not positioned before takeoff, the first positioning point in the air will become "home".

After entering the return home mode, the aircraft will rise to 15 meters, or if it is already higher than 15 meters, it will maintain the current altitude and then fly back to "home". You can also set advanced parameters to "home".

Whether to land autonomously, and how many seconds after hovering to land automatically.



# Mission Planner RTK Setting

## Basic Settings

First, set up the base station. During the base station setup process, the mobile station and UAV flight control do not need to be turned on.

Open the Mission Planner ground station software on your computer and enter the initial setup Optional Hardware RTK/GPS Inject page, you will see the following page:

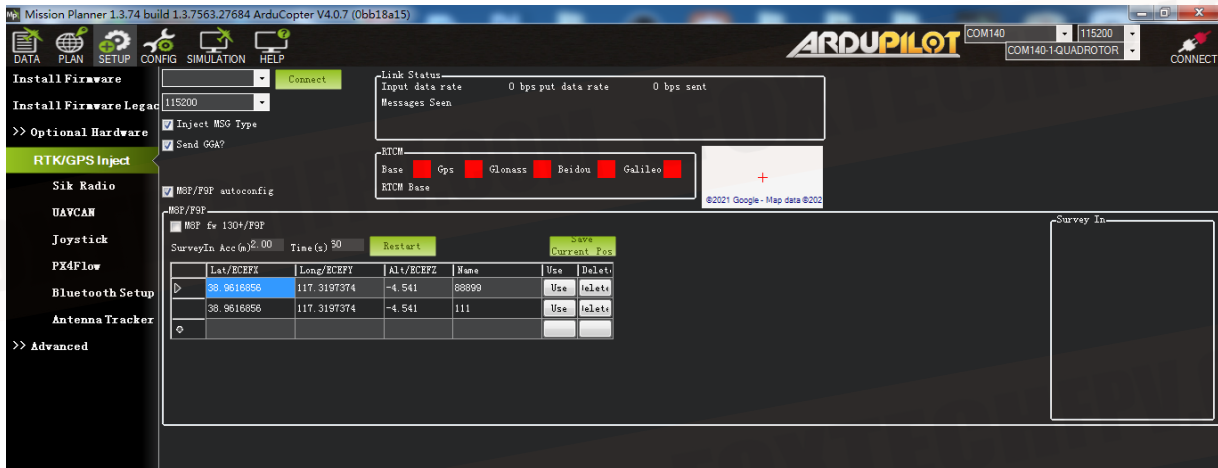

Select the correct base station port in the upper left corner and click connect. In the SurveyIn Acc column, enter the absolute geographic accuracy you expect your HERE+ base station to achieve. In the Time field, enter the shortest search time you expect. Click Restart, the ground station will transmit the data you input to the HERE+ base station, and the base station will start a new round of satellite search and positioning. You will see the following page.

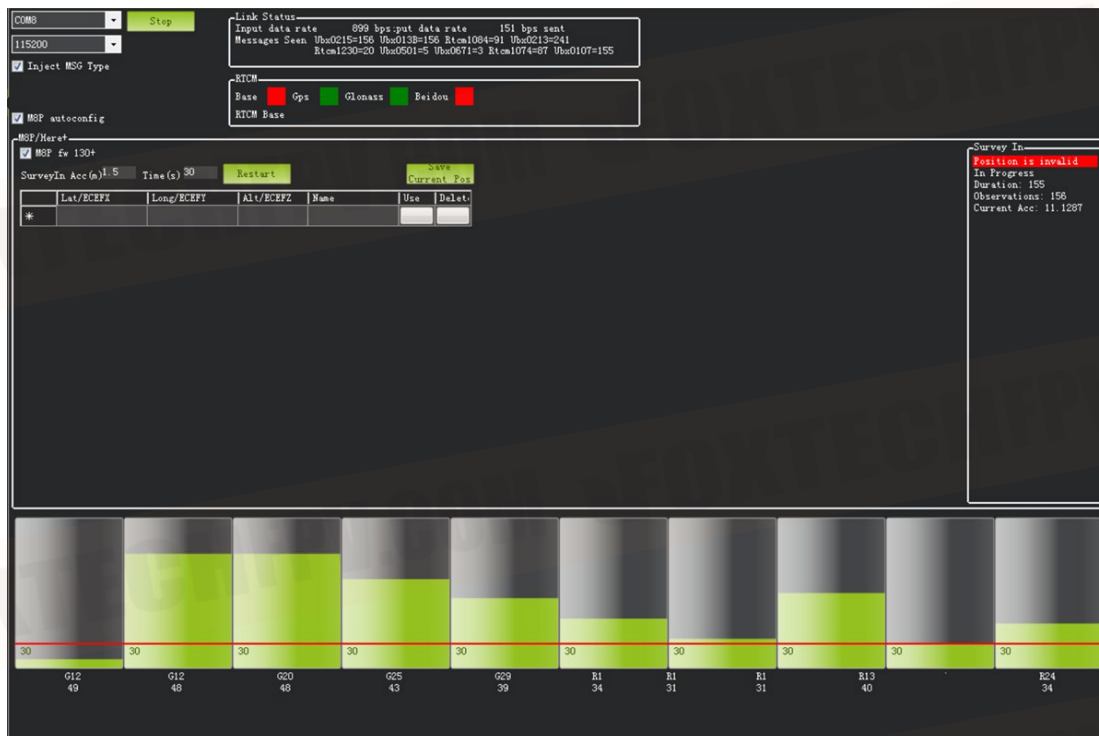

During the satellite search process, the box on the right side of the Mission Planner page will display the current position of the satellite searching:

- Position is invalid: The base station has not yet achieved effective positioning;
- In Progress: satellite Searching is still in progress
- Duration: The number of seconds that the current search task has been executed;
- Observation: The number of observations obtained;
- Current Acc: The absolute geographic accuracy that the current base station can achieve;

The green vertical bar under Mission Planner shows the satellites and the signal strength of the satellites searched by the current base station.

It takes a certain time for the base station to search for satellites to meet the accuracy requirements you input. After testing, in an open and unobstructed area, it takes several minutes to reach an absolute accuracy of 2m, an absolute accuracy within 30cm takes about an hour, and an accuracy within 10cm takes several hours.

It should be noted that the absolute geographic accuracy of the base station here will affect the absolute geographic accuracy of the mobile station, but will not affect the relative accuracy of the base station and the mobile station. If your application does not require drones to have high absolute geographic accuracy, you do not need to set the accuracy of the base station too high, resulting in a longer search time.

Even if the accuracy of the base station is 1.5~2m, the position accuracy of the mobile station relative to the base station can still reach the centimeter level. After HERE+ base station search is completed, Mission Planner will display the following page:

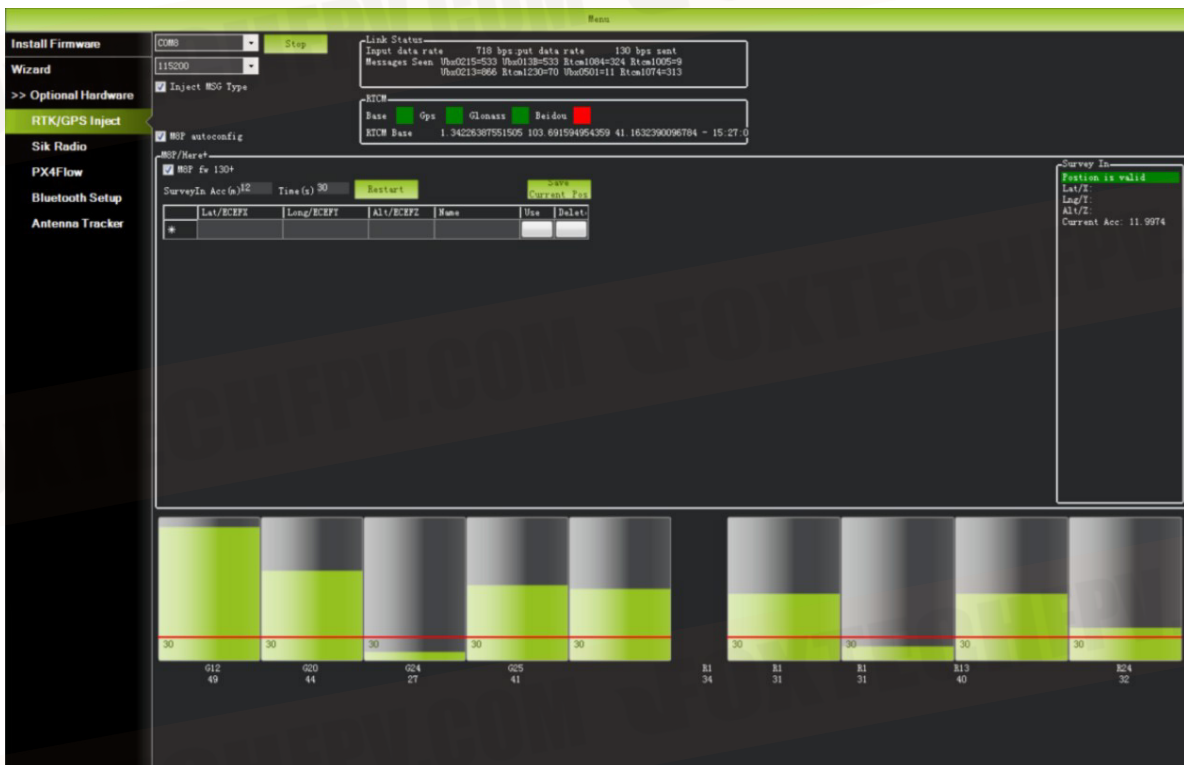

In the figure, the indicator light showing the status of the base station is shown in green, and the two satellite systems, GPS and Glonass, are shown in green (if you want to change the satellite system, please refer to the instructions in the following chapters). The box on the right is displayed as Position is valid.



Store the current position in Mission Planner: Click Save Current Pos, Enter a name in the dialog box and click OK. As shown in the figure below, you can see your storage location in the list. Click on The Use button corresponding to the location you saved, the base station will enter the fixed-point mode, and it will be displayed in the box on the right FixedLLA. Store the current position in Mission Planner: Click Save Current Pos, Enter a name in the dialog box and click OK. As shown in the figure below, you can see your storage location in the list. Click on The Use button corresponding to the location you saved, the base station will enter the fixed-point mode, and it will be displayed in the box on the right. The status is Using FixedLLA.



## How to Use Base Station

Open the Mission Planner ground station software on your computer, enter the initial setup Optional Hardware RTK/GPS Inject page, select the correct base station port in the upper left corner, and then click connect. You will see the following page:



Enter the latitude and longitude of the known fixed station and the measured height of the rtk antenna relative to the ground at the position in the figure below, and then click the use button.

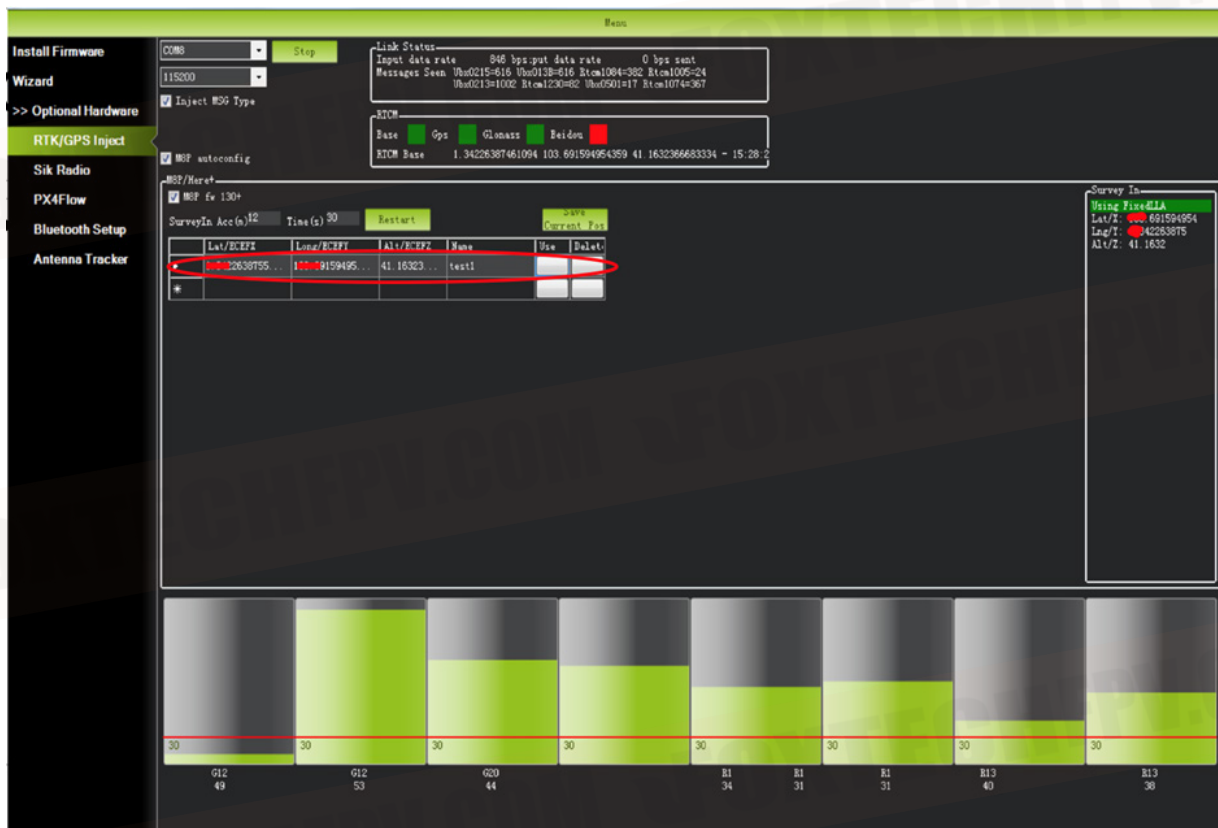

**Note:**The rtk antenna placement position should coincide with the fixed point position as much as possible. The higher the accuracy, the better.

# First Take-off

## Self-checking

The autopilot will do some self-checks when it starts. If any problems are found before takeoff, including calibration failure, configuration errors or poor sensor data, it will be blocked from unlocking. These checks will help prevent the aircraft from taking off under abnormal conditions.



**Under normal circumstances, the LED will flash blue or green. If a problem is found during the self-check, the LED will flash yellow.**

- If the yellow light flashes, please try to unlock. An error message will be displayed in the HUD window. Follow the error prompt to solve the problem. Detailed error information and solutions please refer to the Ardupilot website: [http://ardupilot.org/copter/docs/prearm\\_safety\\_check.html](http://ardupilot.org/copter/docs/prearm_safety_check.html)
- If the blue light or green light flashes, the buzzer will emit a low-pitched sound after unlocking, and the motor will start idling and can take off.

## Meaning of LED Indicator Light

Red and blue flashing alternately: Initialize the sensor and auto-check the autopilot. Please lay down the flight controller.

- Blue flashing: Passed self-check and is in unlock state, but GPS positioning has not been obtained
- Steady blue: Armed but no GPS locked.
- Green flashing: locked state, unlocked state is reached, GPS has acquired location lock.
- Fast flashing green: High-precision positioning such as RTK mode is found. The flight controller is locked and can be unlocked.
- Steady green---the buzzer emits a long beep: the aircraft has been unlocked and is ready to take off.
- Double flashing yellow light: unlock failed, flight refused (check Pre-Arm error message)
- Single flashing yellow: remote control fail-safe protection has been activated
- Yellow flashing-rapid buzzer sound: battery fail-safe protection activated
- Yellow and blue flashing-high-high-high-low (buzzer sound) ; GPS failure or GPS fail-safe protection activated.
- Red and yellow flashing: EKF or inertial navigation failure (error)
- Purple and yellow flashing: barometer error
- Steady red: Hardware error, usually the SD card cannot be detected (re-inserted or replaced), MTD device or IMU sensor, you can check the SD card and the directory BOOT.txt to see the boot information analysis.
- Steady red and SOS beep: SD card is missing or SD card format error, does not light up after power-on, firmware is not burned, firmware is missing, SD card is missing or SD card format is wrong (firmware above ac3.4)

## First Flight

### 1. ARM the drone

Before the drone takes off, it must be unlocked. This will power all motors and actuators. Before unlocking, please make sure to test in an empty environment to avoid accidents. Check in detail whether the hardware installation is correct (especially whether the arm is locked in place, the battery compartment cover is tightly locked, whether the landing gear is locked, whether the external load is installed firmly, the direction of the propeller, etc.). After confirming that there is no problem, perform the following steps :

- Turn on your rc transmitter
- Insert the battery into the aircraft. The flight control status light should flash red and blue alternately (self-check process). Do not move the aircraft during the self-check.
- Pre-Arm will run automatically. After a normal self-check, the blue light or green light will flash, indicating that the Pre-arm has no error and can be unlocked. If the yellow light is flashing, please refer to the FAQ summary to eliminate the error.
- Set the correct mode: Set the mode to Stabilize, ATLhold or Loiter (outdoor GPS lock is required). Novices are recommended to use Stabilization or Altitude hold mode.



**For this product, press the A button on the bottom of the remote control to enter Althold mode**

- Unlock the safety switch: Press and hold the unlock safety switch until the safety LED is always on (flashing means lock and does not output pwm signal, and always on means unlocking and output pwm signal) (the safety switch of this product is disabled, so the user can omit this step)
- Arm the aircraft: There are two ways to unlock the autopilot, which can be unlocked through the ground station or the remote control.

Unlock through the remote control, lower the RC throttle to the lowest position, and the YAW channel to the far right for 2 seconds to unlock it, and then return the YAW channel to the center.



Unlock through the ground station. Under the premise that the autopilot has a link to the ground, there is an action tab at the bottom of the HUD window of the ground station. Click the unlock button inside to unlock.



- ARM Successfully : The propeller will spin up at idle speed to remind that it has been successfully unlocked.
- Take off: raise the throttle to take off, and control the direction according to the attitude (if the novice is not familiar with the control, you can practice the flight simulator first, so as to avoid the explosion of the aircraft and the loss of personnel and property)



**If there is no operation within 15 seconds after unlocking, it will be automatically locked. After unlocking, the ideal attitude is too different from the actual attitude it will be automatically locked.(Such as hitting the roll bar sharply or shaking the aircraft with your hands )**

## 2. Disarm the dromne

perform the following operations to disarm the drone:

- Check your flight mode switch, set to Stabilize, Alt Hold or Loiter.
- Keep the throttle at the lowest and the direction YAW to the left.
- Unplug the aircraft battery
- Turn off the remote control transmitter

### Take-off Precautions

It is best to use the Stabilize mode to take off for the first time. Make sure that the aircraft is flying normally before switching to another mode. The throttle control mode of the stable mode is linear, so the range of throttle control needs to be relatively small.

After flying in the stable mode for a period of time, if the altitude stays above 1 m, you can switch to other functional modes such as altitude hold, fixed point, etc. The throttle control logic of altitude hold and fixed point modes is different. There is a dead zone in the neutral position of the throttle to maintain altitude , Push up, the plane goes up, push down, the plane goes down.



**Note: Before switching to another function mode, you must first understand the characteristics of the flight mode.**

---

# Automatic Mission Planning

Flight planning is one of the most important functions in MP: the average player can use it to plan the simplest flight missions, including height control of each waypoint, stay time, camera trigger, various condition triggers, channel triggers, and even Automatic take-off and landing planning, etc. Industry users can also do surveying and mapping planning and so on.



The main explanation here is the mission planning function of the MP ground station, but the waypoint planning concepts of other ground stations are actually very similar.

- In the MP mission planning interface, create a multi-waypoint area

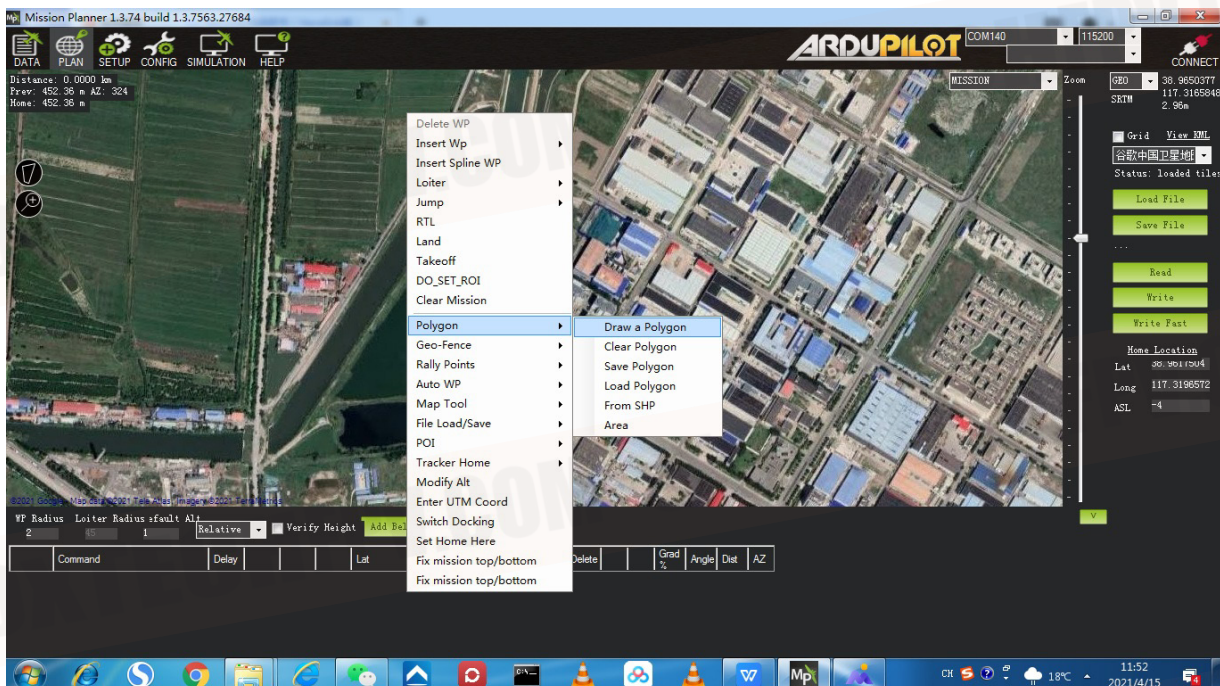

- In the area, click the right mouse button to open the menu and select Automatic Waypoint Survey(Grid)

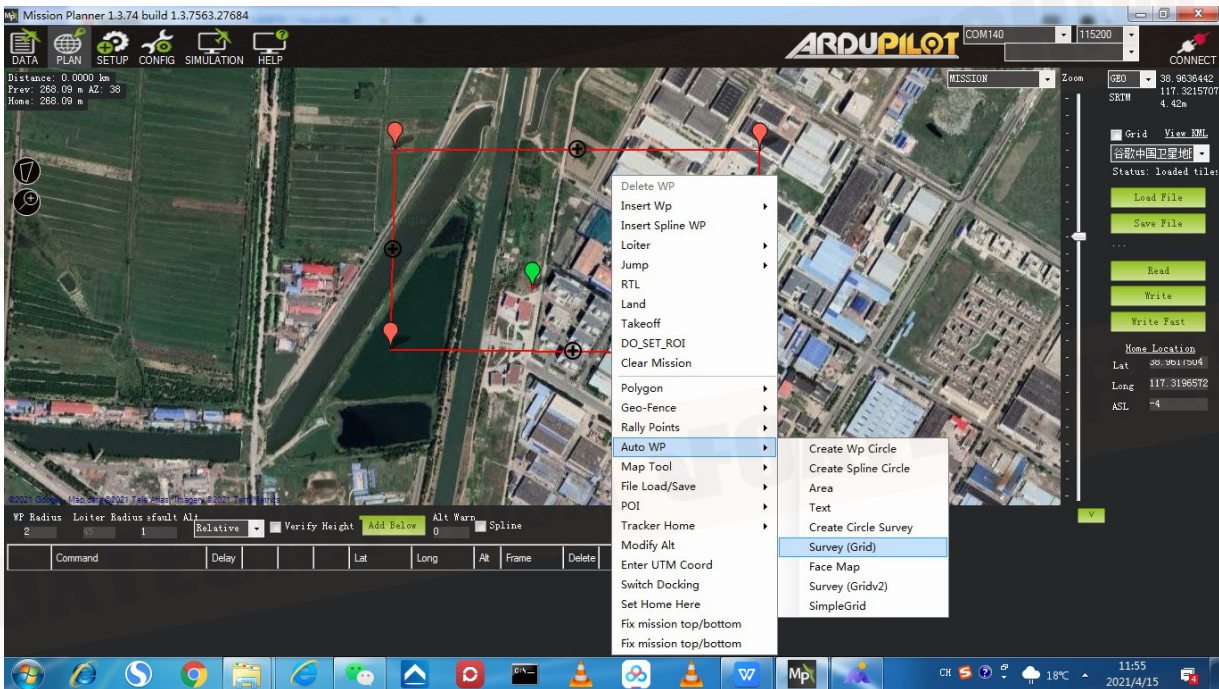

- The mission planner will display the configuration interface. This interface defines the camera parameters and automatically calculates the shooting distance. DO\_SET\_CAM\_TRIGG\_DIST command parameters, you can also set the parameters according to the actual situation.



If you accept these parameters, please click accept, the mission planner will generate a series of waypoints covering the designated area, including the take-off point and the landing point. Call DO\_SET\_CAM\_TRIGG\_DIST command to set the distance of the camera shutter command, and finally call DO\_SET\_CAM\_TRIGG\_DIST again to set the parameter back to 0 and stop taking pictures; note that the parameters of two call are different.



# How to Use Oblique Camera

## Camera Function Buttons



## Camera and Aircraft Connection

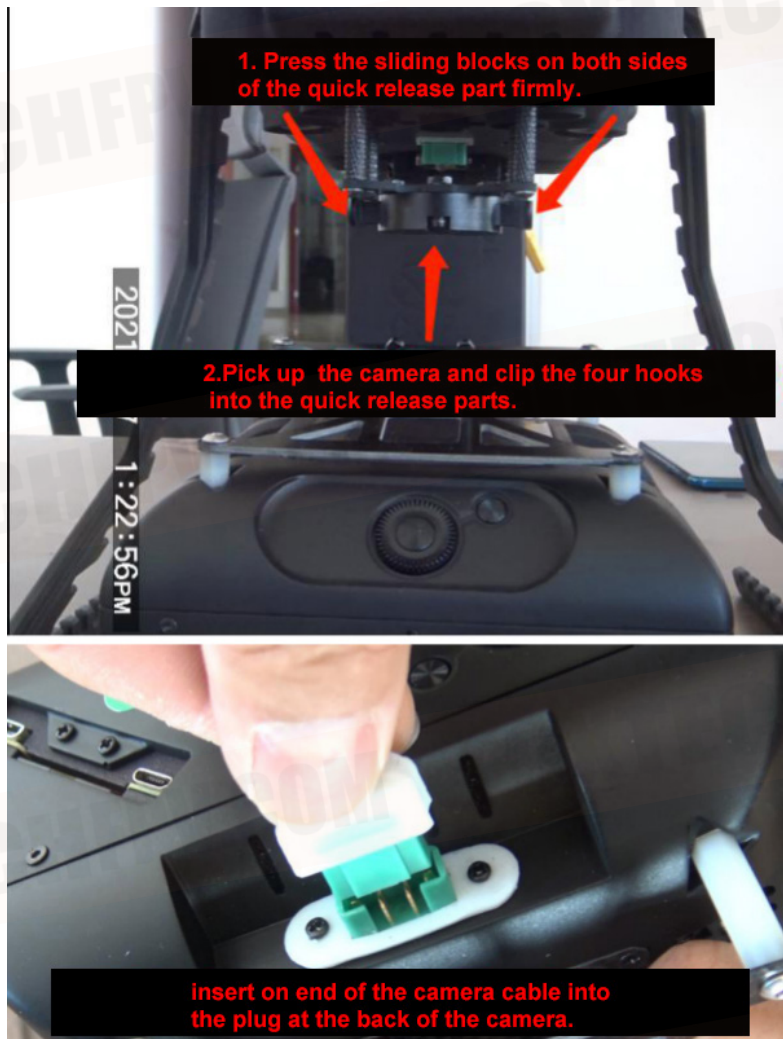

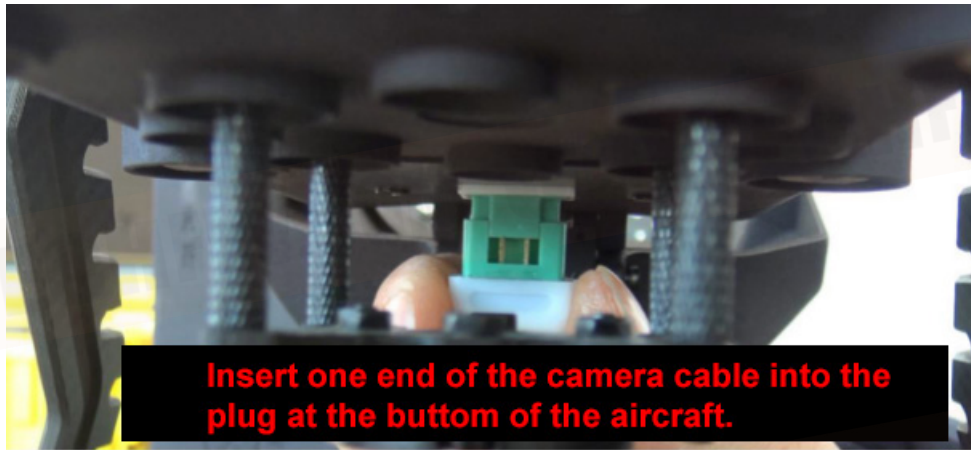

### Photo Taking Test



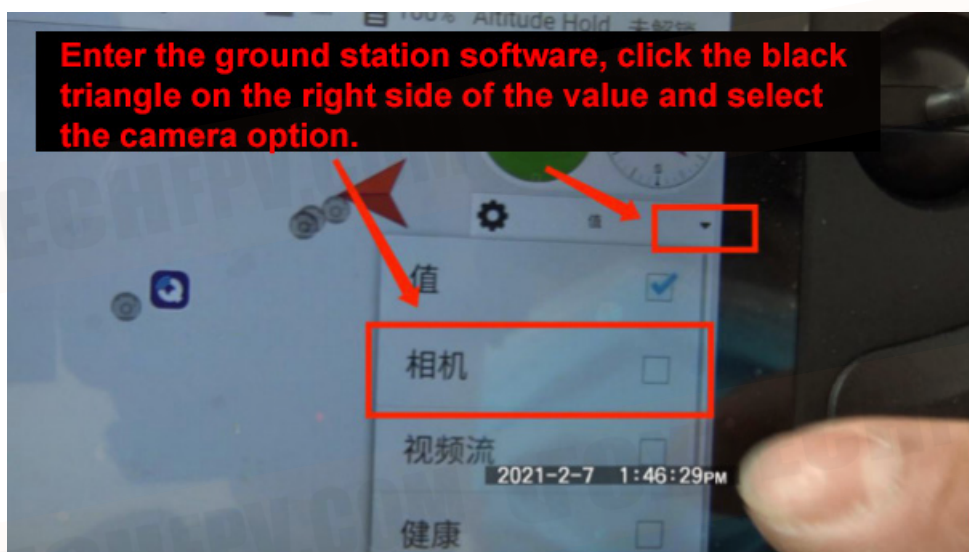
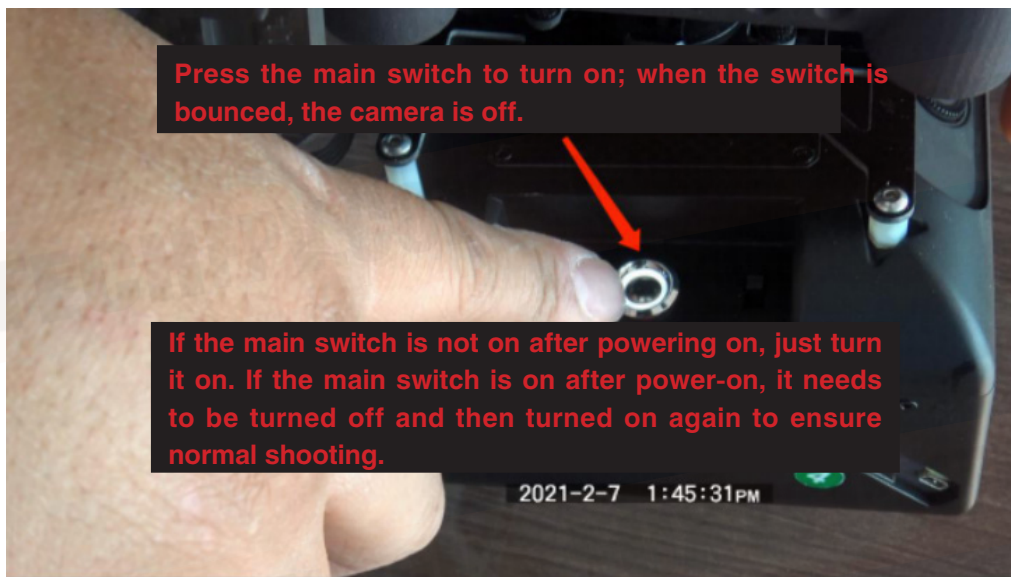

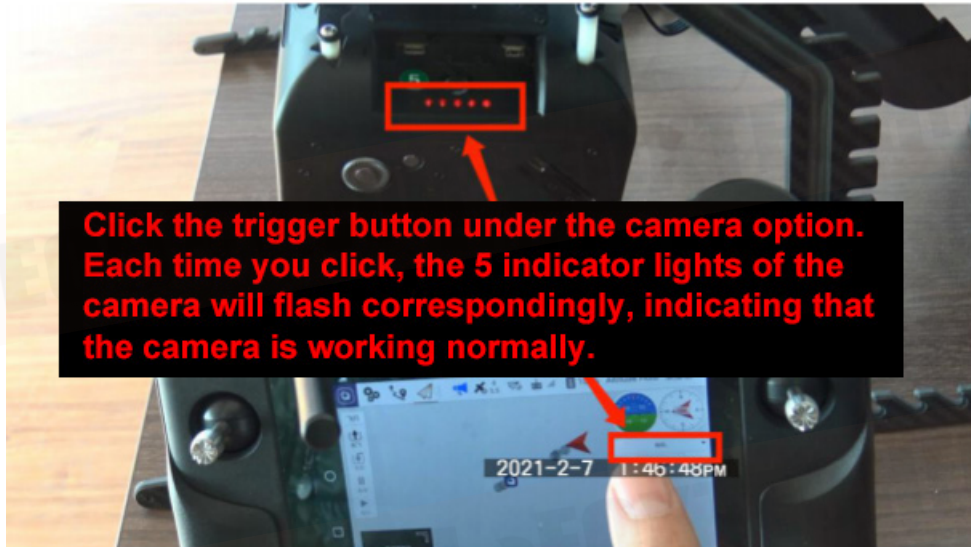

# FAQ

## 1. Bad AHRS

**The cause of the problem:** the acceleration and level are not calibrated, or the calibration is wrong. Added GPS, but the GPS is not fixed, or the GPS arrow is not consistent with the flight control.

**Solution:** Correctly calibrate the acceleration, power off the flight controller after calibration, reconnect, and calibrate the level, this step is very important. Assemble the GPS correctly, make sure the GPS is fixed, and the arrow of the GPS and the arrow of the flight control should be the same. If the flight controller and GPS are integrated, that is to say, when moving, GPS and flight controller are together, and you cannot move one of them. Correctly calibrate the compass. If GPS is added, pay attention to calibrate the dual compass correctly.

## 2. Compass Variance

**The cause of the problem:** If the firmware is updated to version 3.3.3 or above and GPS is added, the above problems will be encountered during debugging. Compass variance means: compass movement deviation. It means that the direction of the built-in compass of the flight controller and the GPS external compass are deviated and inconsistent.

**Solution:** The GPS arrow is the same as the flight control arrow. Fix it. Do not move the GPS or flight control alone. The flight control and GPS must be regarded as one. Do not move one of them alone. Re-calibrate the magnetic compass.

## 3. Bad Accel Health Solution

**The cause of the problem:** the design of the IMU2 power supply of the flight controller is defective, and the low temperature failure occurs in the environment below 5°C. Too low temperature will cause IMU2 to report an error and cause unhealthy acceleration.

**Solution:** The solution is to disable IMU2, which is to set "INS\_USE2" to 0 in "Configuration debugging/All parameter table". If you open the "Configuration debugging/all parameter table", there is no such parameter, please find the "INS\_SPIC" parameter, and change it to 5. If the acceleration error is still reported after this method is operated, please re-calibrate the magnetic compass.

## 4. Check Board Voltage Solution

**The cause of the problem:** If you flash the firmware of multirotor or fixed-wing version 3.5 or higher, and plug it into the computer for USB power supply for debugging, you may encounter this error. It is caused by insufficient USB power supply.

**Solution:** power by battery (Of course, the battery can not directly supply power to the flight controller, use an ESC or BEC or ammeter to stabilize it to 5V to supply power to the flight controller). In the debugging stage, if you must use USB, you can first ignore the function of voltage detection (found ARM\_CHECK in configuration debugging\standard parameters, don't check the board voltage, and others can be checked or unchecked. Remove the check, then remember to click the "Write Parameters" button above, then power off the flight controller and reconnect it.).

## 5. Compasses inconsistent Solution

**The cause of the problem:** Compasses inconsistent means that the compass is out of sync. When we use the dual compass, if the GPS arrow and the flight control arrow are not consistent, this error will be reported.

**Solution:** When using dual compass: fix the GPS, the GPS arrow and the flight control arrow are consistent. The simplest solution is to only use an external compass (that is, GPS compass)

## 6. NO RC Receiver

**The cause of the problem:** The signal input of the receiver is abnormal.

**Solution:** If you are using the PPM encoder board, check whether the blue status light of the PPM encoder is still flashing (you can judge whether the PPM encoder is still working). If using SBUS and PPM receivers, check whether the receiver settings are correct.

## 7. RC not calibrated

**The cause of the problem:** the remote control has not been calibrated, or the range is not within the recorded value of the flight control, usually it is caused by setting the remote control or changing the remote control.

**Solution:** Re-calibrate the remote control.

## 8. Compass not healthy

**The cause of the problem:** The electronic compass is unhealthy. It may also be that there is no value or the hardware is damaged. It may also be that the ambient temperature is lower than 0, which may cause the compass sensor to have no value.

**Solution:** Power on again. If the temperature is too low, please take heat preservation measures, power on again, and check whether the compass value is correct at the ground station-Status MX1 MY1 MZ1 \MX2 MY2 MZ2.

## 9. Compass not calibrated

**The cause of the problem:** the compass is not calibrated, or the compass is removed and added, it will prompt that the compass is not calibrated.

**Solution:** After installing the compass, do the calibration again.

## 10. Compass offsets too high

**The cause of the problem:** The offset value of the main compass (i.e.  $\sqrt{x^2+y^2+z^2}$ ) is greater than 500, and this will be prompted. Generally, there are magnetic objects (motors, screws, battery) near the flight controller or GPS, or the environment has strong magnetic interference.

**Solution:** Please remove the interference and power on again, install the flight controller or GPS in another location, and re-calibrate.

## 11. Check mag field

**The cause of the problem:** If you are indoors, or change to a different environment, or there is magnetic interference nearby, this error may be prompted.

**Solution:** If you change the environment, just do the calibration again. If you are indoors or there is an interference source, just leave the interference source.

## 12. GPS Glitch/ Need 3D Fix

**The cause of the problem:** If the GPS is not positioned successfully or there is no GPS. And the flight mode (Loiter Poshold) that requires GPS is used or the electronic fence is activated, these two error messages will be prompted.

**Solution:** If GPS is not installed or flying indoors, please switch to the flight mode that does not require GPS and wait for GPS to be positioned by 3D FIX.

## 13. Bad Velocity

**Cause of the problem:** The problem may be that the moving speed is too fast, or the accelerometer is not properly calibrated, or the GPS refresh rate is lower than 5HZ.

**Solution:** Wait for the GPS satellites to lock more. HDOP is less than 1.5.

**14. High GPS HDOP** (HDOP is not up to standard, not small enough; the smaller the number, the higher the accuracy )

**The cause of the problem:** The satellite positioning accuracy HDOP is too high, which is generally caused by insufficient satellites.

**Solution:** Put it in an outdoor unobstructed environment. Wait for more satellites to lock on before flying.

#### **15. INS not calibrated**

**The cause of the problem:** the accelerometer is not calibrated, or the calibration is incorrect.

**Solution:** Re-calibrate the accelerometer.

#### **16. Accels not healthy**

**Cause of the problem:** This may be a hardware problem, or it may be that flight controller is started immediately after flashing the firmware.

**Solution:** Re-power on the flight control and reconnect it.

#### **17. Gyros not healthy**

**The cause of the problem:** the data of the gyroscope fluctuates badly, the value is out of range, and there is no data. This may also be a hardware problem, or it is not static when it is powered on, resulting in an error.

**Solution:** lay it flat and turn on the power again.

#### **18. Gyro cal failed**

**The cause of the problem:** usually when the power is turned on (when the red and blue lights are flashing, the power is cut off. Or the value exceeds the peak value will also cause this error message.)

**Solution:** Re-level and power on.

#### **19. Gyros inconsistent**

**The cause of the problem:** The rotation rate of the two gyroscopes differs by more than 20 degrees/sec. This may be a hardware failure or the gyroscope is calibrated incorrectly.

**Solution:** Power on again.

#### **20. Check FS\_THR\_VALUE**

**The cause of the problem:** The current throttle value is too low and the failsafe protection has been triggered.

**Solution:** Check the throttle channel setting of the remote control. The normal value should not be lower than 1000. The most suitable value is around 1100. Check the ground station-Failsafe setting-whether the throttle value is set too high.

#### **21. Fail to ARM and solution**

- **Flight control failure or non-calibration:** Check the error report in the flight data menu in the ground station. Resolve according to the error message. If you want to unlock successfully, the flight controller cannot report any errors. If the accelerometer and geomagnetism are not calibrated, the flight data will show a response failure.

- **the flight control will check the throttle and rudder when unlocked.** The direction of lifting in the ground station is opposite to the direction of your remote control (for example, the remote control lifting channel is down, the ground station sees it is upward), and the other channels are the same as the ground station. If not, it means the channel direction is wrong, reverse setting and then re-calibrate.

- **When the indoor flight is unlocked, the correct flight mode is not selected:** there is no GPS signal indoors, and the fixed-point or loiter flight mode needs to be positioned in flight mode, that is, the flight controller can only be unlocked after finding the GPS signal positioning. Therefore, when the indoor flight is unlocked, you need to switch the flight mode to self-stabilization or fixed altitude flight mode without positioning to unlock. If you select fixed point or loiter mode, you cannot unlock.
- **Failure to press the safety switch on the airplane:** You can set whether a safety switch is required. If the safety switch is effective, you must press the safety switch before unlocking the remote control. The safety switch indicator changes from flashing red to steady red.
- **The remote control joystick is not calibrated:** the throttle joystick is the lowest, and the direction joystick is the rightmost to unlock. Taking the direction channel as an example, the default direction channel of the remote control has the maximum rudder to the right is 1900. If the maximum rudder amount to the right of the direction channel of the remote control is 1800, it cannot be unlocked. You need to calibrate the remote controller in the ground station to let the flight controller know that the maximum rudder amount of the remote control stick to the right is 1800. When the rudder amount reaches 1800, the flight controller knows that the joystick is in the rightmost position, and it can be unlocked.
- **The ESC has not been calibrated:** After unlocking, if you can hear the motor beeping quickly, the ESC has not been calibrated properly. Please re-calibrate the ESC. Refer to the ESC manual for ESC calibration.

## 22. The reason why the camera does not take pictures:

- The 5V output failure caused the optocoupler module to fail to work normally.
- Shooting channel PWM output value reverse.

## 23. Motor does not work: ESC stroke calibration error, re-calibrate.



# Troubleshooting Guide

## 1. The plane tilts severely or turns over when taking off:

This means that it is usually caused by installation or settings. You can check the following points:

- Check if the frame setting X or + is correct
- Check if the ESC serial number is correct
- Check if the motor rotation correct
- Whether the propeller direction is correct and whether the wind is blowing downwards
- If the accelerometer calibrated correctly
- If the ESC throttle is synchronized

## 2. The aircraft cannot take off when the motor rotates or the motor will not rotate when unlocked:

- Check whether the wind is blowing downwards (propeller installed incorrectly, motor turning incorrectly)
- Insufficient power? Check whether the propeller size matches the battery voltage in the motor parameters
- The motor does not respond and keeps screaming: the throttle range of the remote control is not calibrated

## 3. Controlling the aircraft to fly forward but actually flying backward or controlling to left but actually to right:

- The control channel of the remote control is reversed, just adjust the corresponding channel of the remote control menu to reverse it.

## 4. The flight controller cannot detect the remote control signal:

- If it is the first time to use: first check whether the receiver is paired successfully? Whether the receiver output is PPM or SBUS protocol, if not, please use a PPM encoder.
- If it was normal before, it suddenly fails: Maybe the receiver is faulty or the IO of the flight controller is faulty.
- After flashing the PX4 native firmware, it is abnormal: it may be that the IO firmware or BootLoader has been broken.

# How to Use QGC

For the use of QGC ground station, please refer to QGC official website:

<https://docs.groundcontrol.com/master/en/>

This content is subject to change.

Download the latest version from

<https://www.foxtechfpv.com/foxtech-naga-quadcopter-mapping-package.html>

For everyday updates, please follow

Foxttech Facebook page: <https://www.facebook.com/foxtechhobby>

YouTube Channel: [https://www.youtube.com/user/foxtechonline/featured?view\\_as=subscriber](https://www.youtube.com/user/foxtechonline/featured?view_as=subscriber)