

# Archer

## AAT Auto Antenna Tracker Gimbal

User Manual

V 1.1 2021.11



### **Disclaimer**

Thank you for purchasing this product. you can log in to the website for the latest product information, technical support and user manual. It is recommended that you download and use the latest version of the user manual. This manual is subject to change without notice.

You can also get product usage information or technical support through official customer service. Due to different production batches, the appearance or function parameters are slightly different and will not affect the normal use of the product.

Please read this statement carefully before using. Once used, it is deemed to be an endorsement and acceptance of the entire contents of this statement. Please read the instruction manual carefully and strictly follow the instructions in this manual to install and use this product. Foxttech will not be liable for any result or loss caused by improper use, installation, assembly or modification of users.

### **Intellectual Property**

The intellectual property rights of this product and manual are owned by Foxttech. Any organization or individual may not copy, reproduce or distribute in any form without written permission. If you need to quote, you need to indicate the source, and you should not make any modifications, deletions and references to this manual.

## 1. Product Introduction

Archer AAT is designed for use with unmanned aerial vehicle (UAV) on-board antenna system. Its purpose and objective is to point the antenna precisely in the current direction of the aircraft thus allowing the video receiver to pick up the strongest signal possible at given distance and other factors.

In order to obtain better signal reception quality, it is advised to use high-gain receiving antennas. High-gain antennas are known for very narrow angles of effective reception. For its successful operation, Archer AAT requires the flight data such as latitude and longitude of the tracked target (UAV) at every given moment, as well as its altitude.

This is achieved by the following:

1. Transmitting information of the tracked target over a wireless analog video link from the UAV to the ground station. For that, the UAV must be equipped either by a MFD Auto Pilot, or a MFD Crosshair Auto Pilot, or in case a third party AP is used with a MFD TeleFlyTiny tracking module.

**ATTENTION:** Using TeleFlyTiny module is possible with many third party flight controllers. MFD does not guarantee that it works with any particular make or model of the autopilot, nor that it will continue to work with any third party autopilot after its firmware or software is updated.

2. Transmitting information of the tracked target over a wireless High Definition video link from the UAV to the ground station. For that, the UAV must be equipped either by a MFD Auto Pilot, or a MFD Crosshair Auto Pilot, or a MAVLink-compatible Auto Pilot, or in case a third party AP is used, an MFD TeleFlyTiny tracking module. The signal containing encoded tracking data from the TeleFlyTiny module on the aircraft will be transmitted to the Archer AAT through the serial port .

3. Transmitting information of the tracked target over a wireless digital data link from the UAV to the ground station. MAVLink protocol allows to transmit the information from the UAV through the digital radio link. If the on-board system already includes the digital radio, and the flight controller that supports MAVLink protocol, Archer AAT will be able to receive all flight information necessary to track the UAV through the shared TXD line of the digital radio station.

4. For more specific applications requiring custom design of the signal transmission, please contact MFD directly.

Specifications		
Tracking Ability	MAX Pan-Speed	300deg/s
	MAX Tilt-Speed	60deg/s
	MAX Pan-Angle	Unlimited/450deg
	MAX Tilt-Angle	-15deg~135deg
Mechanical/Electrical specifications	Weight	2.6kg
	MAX Tilt Torque	14kgf.cm
	Operating Voltage	12~16V DC
	Power Consumption	< 15W (Typical)
Protocol Interface	MFD VBI	All MFD Autopilots/TeleFlyPro/TeleFlyTiny supported
	MAVLink	MAVLink V1.0/V2.0 supported

## 2. Installation and wiring

1. The AAT can be fixed on the head of a regular camera/camcorder tripod by the means of a standard 1/4-20 threaded interface at the bottom of the main unit. Make sure the tripod you use is capable of supporting the size, weight, and leverage of the battery+AAT+Antenna assembly. Correct choice of a tripod is the user's responsibility. Please make sure that the quick release plate of the tripod is compatible with the threaded interface on the bottom of the AAT main unit.

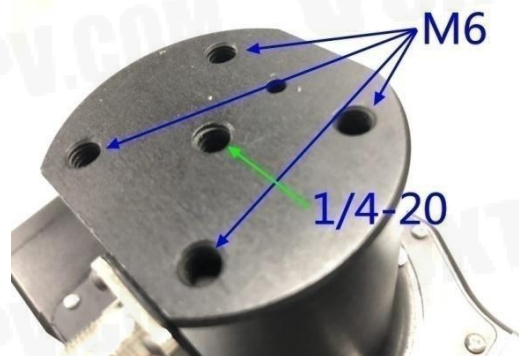

Archer AAT requires =12V to 16V (3S~4S) DC power supply. The recommended power supply solution is 2 x NP-F980 batteries (7.4V 6600mah).



The tracker is powered on by simply plugging the XT60 connector into the corresponding power socket of the AAT, as shown in the picture:



2. The antenna has to be mounted on the Archer AAT with the use of a special bracket. In order to prevent tampering with the normal operation of the compass built into the Archer AAT it is recommended to avoid using antennas made with ferromagnetic materials. Wherever possible, use non-magnetic stainless steel bolts, aluminum and other non-magnetic materials.

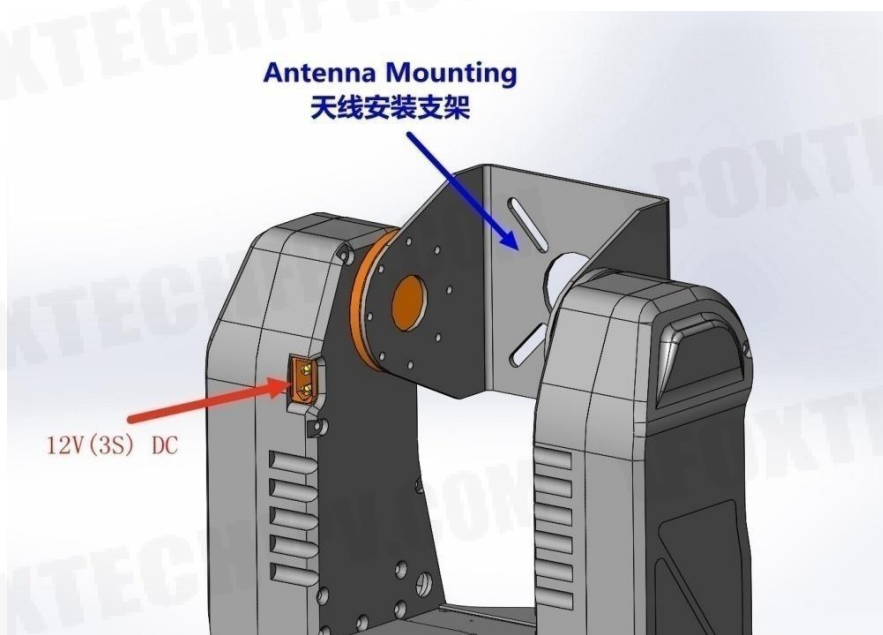

3. There is an aviation-socket on the main unit(the upper connector), and a cable with aviation-plug and color coded wires.

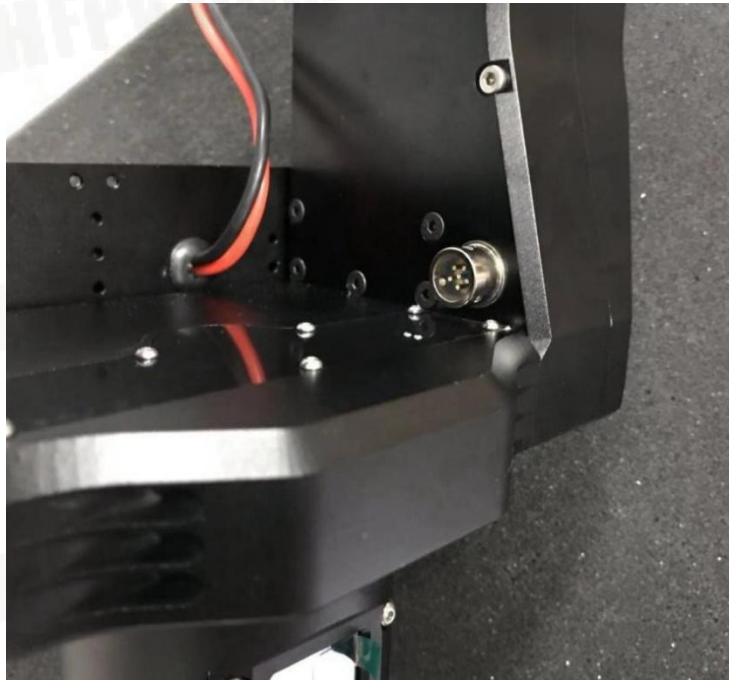

Please connect it to your equipments using the following color coding diagram:

Upper Connector Cable Color Definition		
Pin#	Wiring Color	Definition
1	Red	12V~16V power supply (shared AAT power supply voltage)
2	Yellow	Analog video input
3	Gray	External GPS RX (U2 RX). This pin maybe not available in later version. The UART2 has been move to the top of the LEFT ARM of Archer.
4	Orange	Telemetry Data TX(U3 TX) (connected with RX of your DataRadio)
5	Blue	Telemetry Data RX (U3 RX) (connected with TX of your DataRadio)
6	Black	Ground

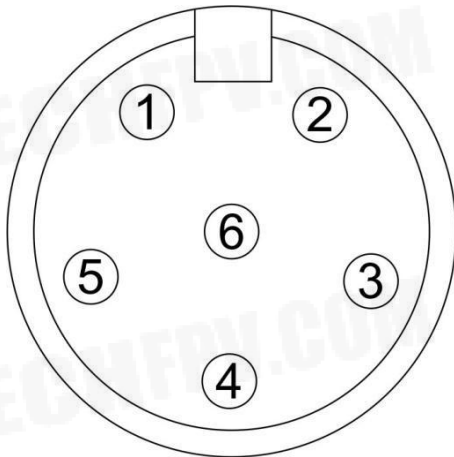

1	RED	+12V OUT
2	YELLOW	VIDEO IN
3	GRAY	GPS RX
4	ORANGE	U3 TX
5	BLUE	U3 RX
6	BLACK	GND

If you wish to use MAVLink protocol to provide tracking data through digital radio link:  
Fix the digital radio link on the antenna bracket.

Connect the black wire of the plug cable to the ground wire of the digital radio link. Connect the red wire to the power wire of the digital radio link.

**ATTENTION:** Voltage supplied via the red wire(=12 to16V) may be different from the digital radio needs. Please use a suitable power conversion module if the digital radio power voltage is different from the above mentioned.

Connect the TX (data output line) of the digital radio link to the green line of the cable.

Power on the digital radio link.

Usually, the UAV ground station also needs to be connected to the digital radio link. Sharing the TX line of the digital radio link with Archer AAT will not affect the normal ground station operation.

4. There is a Archer RF model which uses a RF-Slipring inside. With this RF version, users can mount their antenna on the tracker and access the signal (Up to 3GHz) with the lower NConnector of the Archer .

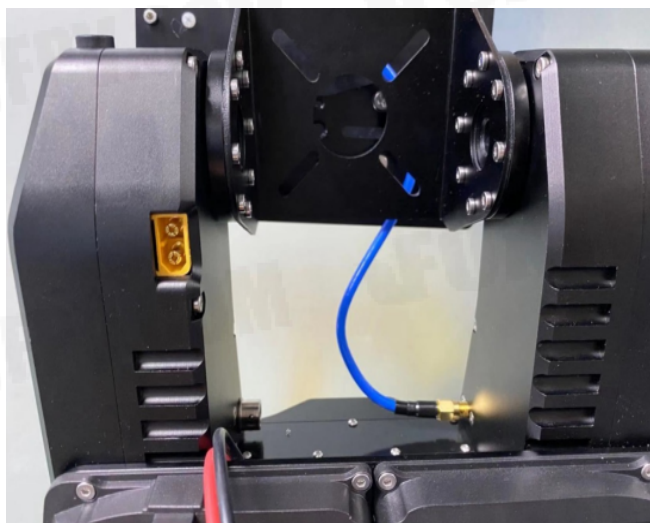



### Archer AAT Lower Connectors Descriptions

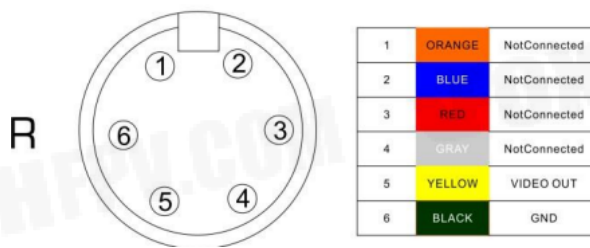
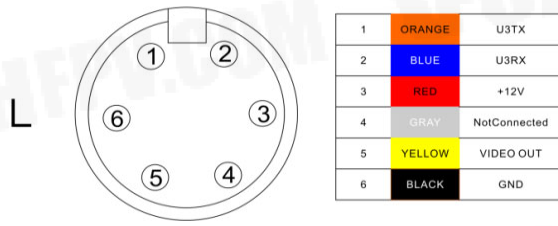

Lower Left Connector Cable Color Definition		
PIN #	Wiring Color	Definition
#1	Orange	Telemetry Data TX(U3 TX) (connected with RX of your DataRadio)
#2	Blue	Telemetry Data TX(U3 RX) (connected with TX of your DataRadio)
#3	Red	12V~16V power supply (shared AAT power supply voltage)
#4	Gray	Not Connected
#5	Yellow	Analog video output
#6	Black	Ground

5. Choose the GPS+Compass module to get better tracking performance:



The Archer will recognize the GPS+Compass module once it's plugged. The screen will display something like GPS:12/L14 to show the number of satellites locked by remote GPS/ local GPS. With this module, The tracker will start to track when it locks enough satellites without setting home operation.

### 3. Test

Please make sure the tripod is securely set up, and its legs are well tightened. Then power on the AAT.

Normally, the tilt angle will return to the horizontal 0 degrees (pointing to the horizon), and the AAT will be rotate several times for initialization. The following information will be displayed on the OLED screen of the Archer AAT:

```
GPS: 12 (Batt:12.1V)
DIST:N/A
Alt: N/A
AZim: N/A
VLink: 0%
Dir: 0
```

Main Screen Descriptions	
Display Item	Description
GPS/LocalGPS Batt	GPS Satellites locked. If an external GPS is connected, GPS/LocalGPS will be displayed in 12/11 formation (GPS=12, Local=11) Batt (Voltage of the main battery) will be displayed alternatively here.
Dist	Distance of the plane (Not Available before SetHome)
Alt	Altitude of the plane (Not Available before SetHome)
Azim	Azimuth of the plane (Not Available before SetHome)
VLink/DLink	Video/Data downlink quality. (in %, ref to the "Downlink" chapter)
Dir/EDir	Current heading direction of the tracker. If an external compass is connected, EDir will be displayed alternatively

When you get enough satellites locked (usually 8 or more), press the right button on the base to SetHome for the tracker. With MFD AP/MFD Crosshair you can SetHome for your plane, meanwhile the Home location of the tracker will also be set.

Once the plane flies to 10 meters away, the tracker will start to track.

Archer can work in 2 modes: Unlimited/450degrees.

In Unlimited mode the Archer AAT can rotate in one direction continuously.

In 450degrees mode, The tracker will rotate back 360 degrees when it reached its limits (to avoid twisting cables between tracker upper rotating part and the ground devices. To use 450deg mode, please turn the tracker manually to point to your favorite direction (the opposite direction is rarely used in the flight). Then hold the right button of the tracker for 3 seconds or longer. The heading direction of the tracker will be stored as the current favorite direction until power off.

The below diagram describes how 450deg mode works.

We assume that the plane is circling above the tracker in counterclockwise direction (Top view, Look from the sky). The tracker starts from the point A. It rotates 360 degrees in CCW direction.

It won't rotate in opposite direction immediately now to avoid oscillating in this position. It keeps rotating until it reaches the point B. To avoid twisting cables the Archer will quickly rotate 360 degrees clockwise and point to B again.

If the plane circles clockwise, something similar will happen in the opposite way. Mostly the tracker can rotate  $360+45+45=450$ degrees. That's why we call it "450degrees mode".

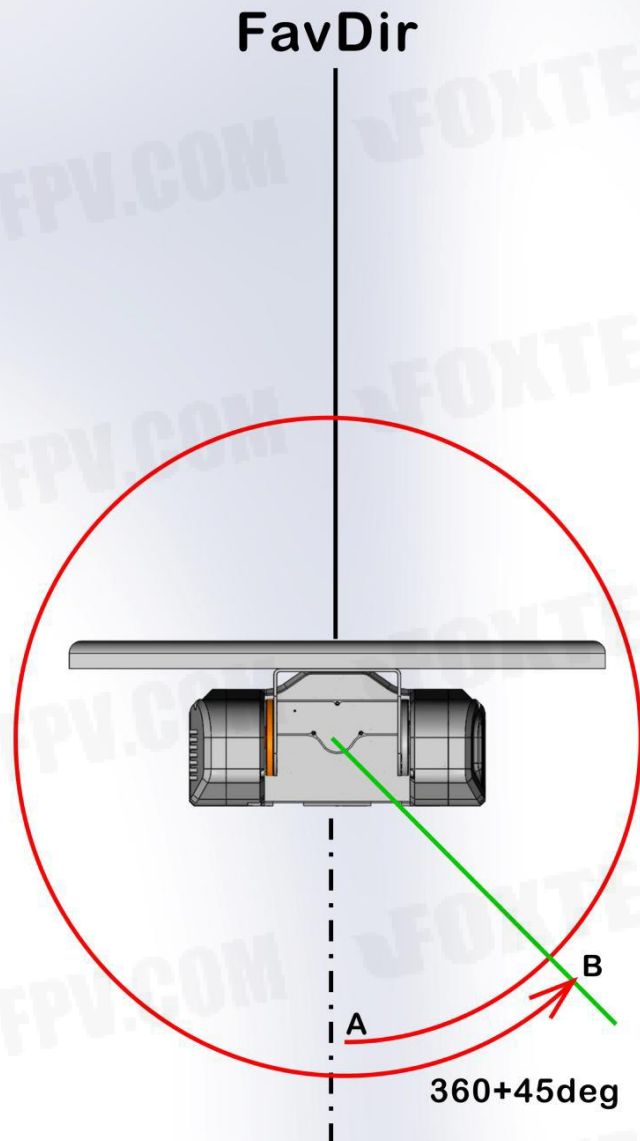

#### 4. Downlink

The Archer AAT needs a downlink to get the information of the tracking plane.

Usually this is the most difficult part to get your system to work. Because you have to merge several devices came from different manufactories.

We may extend this chapter in the future. Currently we discuss dataradio solution(Based on MAVLink).

**2. DataRadio (MAVLink):**

With a pair of DataRadio you can send data from the plane to your tracker. There are many protocol can be use to establish a downlink, private ones, and open ones. MAVLink is one of the most popular ones. It's not perfect but it's common. Many autopilots support it, including MFD Crosshair AP.

If you use a Pixhawk/ArduPilot device, I assume you already connect your DataRadios and they are working well. Now we are going to integrate the MFD Archer AAT to your system.

The DataRadio device can be mounted to the tracker and rotates together with the tracker. In this case the tracker still has the ability to rotate continuously without any limitation.

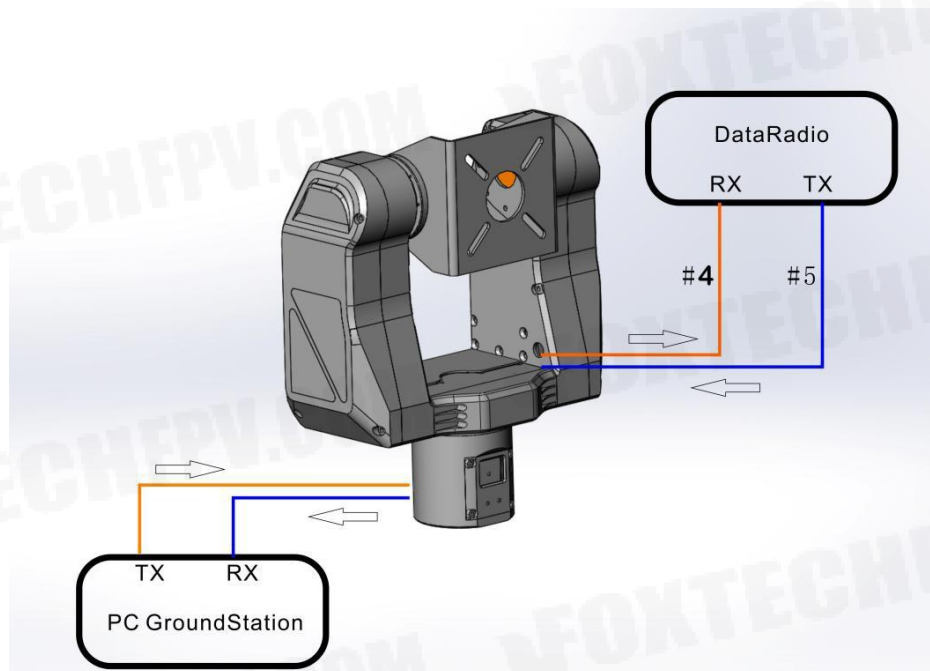

Connect your GroundStation to the DataRadio via the sliping of the Crossbow AAT

But if the DataRadio is very heavy or you have some other reasons to keep it on the ground, you have to connect a cable from your antenna to your DataRadio in this case. You need to set FavDir (Favorite Direction) of your flight. The tracker will work in 450 degrees mode to avoid twisting cables.

Finally you have this solution: The tracker pitch/yaw the antenna only. Your DataRadio stay on the ground and connect with your antenna via feeder cables.

No matter where you install your DataRadio, you need to share its TX line to #5(Blue) wire to the upper-connector of the tracker.

#### **Note: About the MAVLink**

The MAVLink protocol has been used/implemented in many Flight Controllers, Ground Control Stations(GCS) and trackers. But actually many devices use the MAVLink in their own way. One of the reasons is that MAVLink is not clear enough to define how to send some important data between the Plane And GCS. There are so many different MAVLink messages which can be used to send GPS Coordinates, Altitudes...

Archer AAT needs both these 2 MAVLink messages to track.

**MAVLINK\_MSG\_ID\_GPS\_RAW\_INT**

**MAVLINK\_MSG\_ID\_GLOBAL\_POSITION\_INT**

If the Archer AAT receives some correct MAVLink data packs (Heartbeat?) but not able to find the above 2 messages, it will display "DLink:1% msg?" to remind you to check if the above 2 messages are sent at 1Hz or a higher frequency.

In Archer AAT, If you choose menu "Protocol->ALT=BARO",

**MAVLINK\_MSG\_ID\_GLOBAL\_POSITION\_INT.relative\_alt** is used as the data source of the altitude. This works for most ArduPilots. (APM), and MFD Crosshair AP.

You can check "FlightInfo-> ALT/BARO" to read the current GPS-ALT and Baro-Alt. Archer uses "Baro" Alt to track.

Another option is "Protocol->ALT=GPS". In this case, **MAVLINK\_MSG\_ID\_GPS\_RAW\_INT** will be used as the data source of the altitude. This works for most PIX4 Flight Controllers.

In this case, "FlightInfo-> ALT/BARO" are both from **MAVLINK\_MSG\_ID\_GPS\_RAW\_INT** message.

We recommend our users to set the update frequency of the above 2 messages higher to get better tracking performance. The method varies from different Flight Controllers. Take the ArduPilot Mega as an example, you can search for string"SR1\_" in Mission Planner "All parameters List" to get a table of MAVLink messages updating frequency for Telemetry1 port.

Please set SR1\_POSITION to 5Hz or higher in this case. 0=Disable.

SR1_EXTRA2	0	Hz	0 10	Stream rate of VFR_HUD to ground
SR1_EXTRA3	0	Hz	0 10	Stream rate of AHRS, HWSTATUS,
SR1_PARAMS	0	Hz	0 10	Stream rate of PARAM_VALUE to g
SR1_POSITION	0	Hz	0 10	Stream rate of GLOBAL_POSITION
SR1_RAW_CTRL	0	Hz	0 10	Stream rate of RC_CHANNELS_SC
SR1_RAW_SENS	0	Hz	0 10	Stream rate of RAW_IMU, SCALED,
SR1_RC_CHAN	0	Hz	0 10	Stream rate of SERVO_OUTPUT_R

**TroubleShooting:My DataRadio doesn't work with Archer. Only VLink:0% is displayed**

1. Check if the tracker is receiving data from your date radio. Check Menu item "Factory->CoreData->RX". This number will increase when the tracker receives any data from U3RX (Datalink port) or U2RX(External GPS port). If the RX doesn't increate at all, please check your cables again and make sure your DataRadio is sending out date on its TX wire.
2. Check menu "BaudRate" again to make sure you are using a proper baudrate, especially after you apply a new firmware.

**5. AAT menu operation guide**

After power on the screen shows main parameters of the current status.

```
GPS: 12
DIST:N/A
Alt: N/A
AZim: N/A
VLink: 0%
Dir: 0
```

To enter/quit the menu system, hold the LEFT button for 2 seconds or longer.

You can also choose "Exit" in the menu to quit the menu system.

Please use the LEFT button to browse the menu.

Use the RIGHT button to enter sub-menu or change values.

```
MAIN MENU
YawTrim
HomePos
CalCompass
MotorCurr
CalPitch
CompassMod
BaudRate
FlightInfo
PayloadSel
OSDLevel
VBISetting
Protocol
TrackerID
SysInfo
Factory
Exit
```

#### **YawTrim:**

```
<<[-][+]>>
Yaw:0
Pitch:0
Exit
```

If the tracker is slightly tracking the plane left or right, you can apply some YawTrim to make it more accurate. Use Negative values to trim the tracker to LEFT. Use Positive values to trim the tracker to RIGHT.

You can also use the Pitch item to trim the tracker UP/DOWN.

The valid parameter range is [-20,20]



**HomePos:**

```

UsePreHome
H1:D:0
H2:D:0
H3:D:0
H4:D:0
H5:D:0
AutoLoad=N
Exit

```

H1~H5 is the Home Positions which you recently have used. H1 is the most recent home position. H5 is the earliest one.

The distances between your plane and the H1~H5 stored home positions are displayed in a D:XXXXX formation. Also the longitude and latitude of each home position will be displayed alternatively to help the user to decide which Home Position should be load to use.

Click the right button to load a high-light (selected) home position.

If you forgot to Set Home before takeoff, this function will be helpful especially you have a proper pre-saved home position in the tracker.

AutoLoad=N means the tracker will not load the most recent home position when it starts up. Click the right button to set AutoLoad=Y to enable it.

**CalCompass:**

```

CalCompass
MAX:125
...
...
Exit
AutoLoad=N
Exit

```

Click the right button to execute a compass calibrate the compass of the tracker.

Before doing that please make sure the tracker is locked on the tripod well.

It takes about 20 seconds to finish the calibration. You can ignore the parameters showing on the screen during the procedure.

**MotorCurr:**

```

MotorCurr
Pit:2000
Yaw:2000
AutoDetect
Exit

```

Use the right button to set the maximum current for the Pitch or Yaw motor. (in mA)

Valid range of these parameters are [0,4500] mA

You can also use "AutoDetect" to measure the proper settings of your setup. Remember to fasten your tracker and clear all objects nearby before doing that. Because the tracker may yaw and pitch to any direction during the procedure.

**CalPitch:**

```
CalPitch
Pitch UP
Pitch DOWN
Save L Pos
Save H Pos
Save & Exit
Exit
```

Use this function to calibrate the pitch sub-system of your tracker.

Tracker needs to know the horizontal position to work well.

Please follow these instructions to Cal. Pitch:

1. Use "Pitch UP" and "Pitch DOWN" to adjust the tracker until it points to horizon. (Imaging that the plane is very far and low).
2. Use "Save L Pos" to save this Low Position.
3. Use "Pitch UP" and "Pitch DOWN" to adjust the tracker until it is about 110 degrees. (Not restrict 110 degrees, but it must > 90 degrees.) That means the tracker reaches vertical position and goes further.
4. Use "Save H Pos" to save this High Position.
5. Save & Exit.

**CompassMod:**

```
UseCompass
InitOnly
Always
Never
ExtGPS=Y
Exit
```

This setting is about how to use the compass of the tracker.

ExitGPS=Y/N. Use the external Compass or only use the internal Compass.

**InitOnly:** The tracker only reads the compass to know where is North when starting up. Later it will use an internal optical-encoder to work smoothly without the compass. In this case you can't rotate your tripod because the tracker is not able to sense that movement.

**Always:** The tracker use the compass all the time (Just like our 1st generation MFD AAT). With this option you can even mount your tracker on a vehicle and keep tracking (with an external Compass+GPS). But if you are using the built-in compass, this option is not recommended because the internal compass is not very accurate when the motors work at high-payload status.

**Never:** The tracker doesn't use the compass at all. You are responsible to point the tracker to North. (That means facing the AAT Screen to South). If you are going to fix the tracker on a building you can use this option.

**BaudRate:**

```
Baud Rate
203400
115200
57600
38400
19200
9600
4800
1200
Exit
```

Choose a downlink baudrate to match your dataradio setting.

**FlightInfo:**

```
FlightInfo
Lon:EAST
0.000000
Lat:NORTH
0.000000
ASL:0m
BARO:0m
Exit
```

This screen displays some useful information of the plane which is being tracked.

Lon/Lat is the GPS coordinates of the plane.

ASL: AboveSeaLevel altitude of the plane. Usually comes from the GPS data of the plane.

BARO: Barometer altitude of the plane. Usually comes from the barometer of the plane.

**PayloadSel:**

```
Payload
Light
Midium
Heavy
UltraHeavy
Exit
```

Choose the payload level of your setup.

Light: Light Weight antennas, high acceleration and fast movements.

UltraHeavy: Very Heavy antennas, low acceleration and slow movements.

**OSDLevel:**

```
Brightness
Level:90
Exit
```

Choose the OSD(OnScreenDisplay) brightness level of the tracker. The tracker is able to overlay some graphics information on the analog video signal. Higher value will choose brighter OSD images. With the CAN-BUS and our new "FlyTogether" feature, users now can connect up to 10 trackers. Everybody can see other's relative position/altitude on the screen.

Valid range of this parameter is [0,100].

**Protocol:**

```
Protocol
ALT=BARO
LNK=ANALOG
UseASL=N
Exit
```

Choose LNK=ANALOG or LNK=DIGIT to determine the downlink you are using. Usually when you are using digital protocol you should choose LNK=DIGIT here.

Choose UseASL=N or UseASL=Y to determine to use local GPS-Compass module ASL(Above Sea Level) or not when setting Home point. If UseASL=N, the target altitude will be considered relative to the Home point. If UseASL=Y, the target altitude will be considered relative to the Sea Level.

Choose ALT=BARO or ALT=GPS to determine what altitude data of the MAVLink data stream will be used to track. We will discuss this in the chapter "5. Downlink".

**TrackerID:**

```
TrackerID
ID=1
Exit
```

Choose the numeral ID of the tracker. When you use "FlyTogether" function, your ID will be displayed on other's OSD screen. You need a unique ID when you joining a "FlyTogether" CAN-Bus network.

The valid range is [0,9]

**SysInfo:**

```
SysInfo
Ver.:1.83
2:21.8.23
12:40:22
Hw:1
Exit
```

This screen shows version number of the firmware (1.83) and Hardware (1)

**Factory:**

```
Test
YawTest
```

PitchTest

AllTest

CoreData

Exit

This screen is reserved for the manufacture.

## Appendix A:

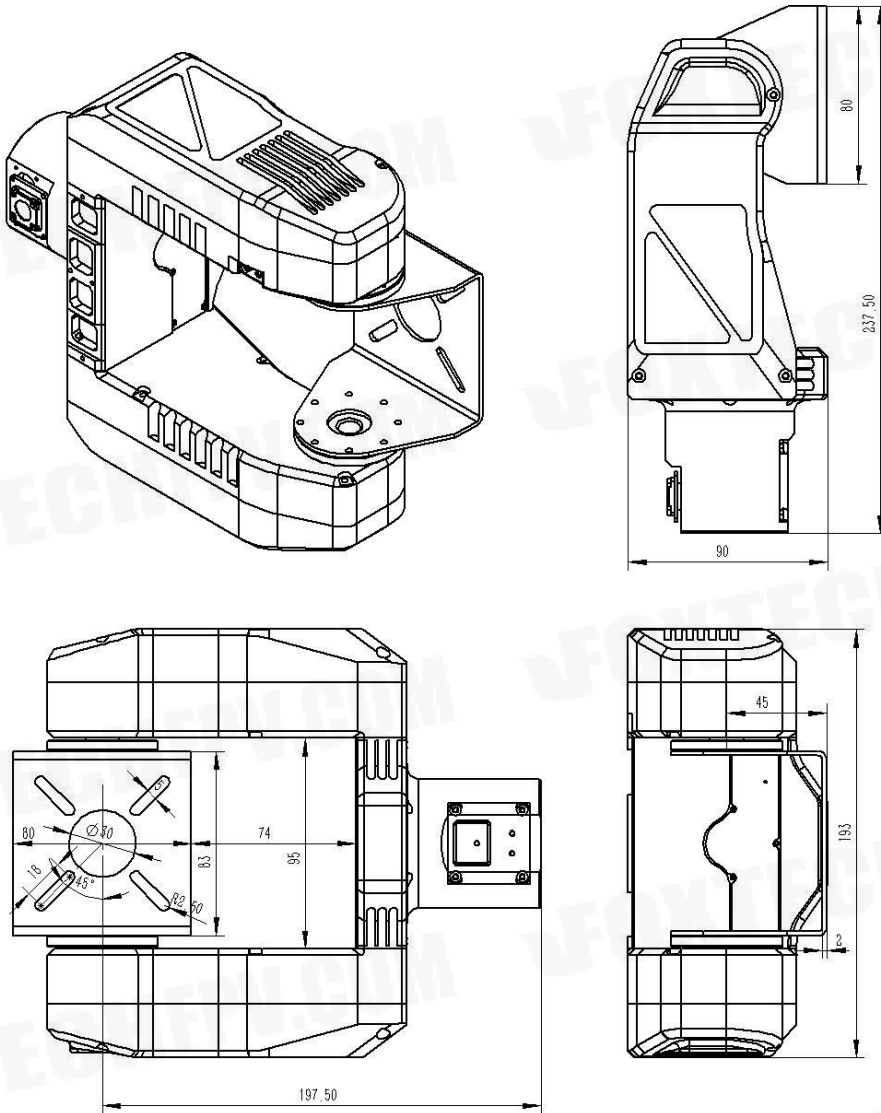

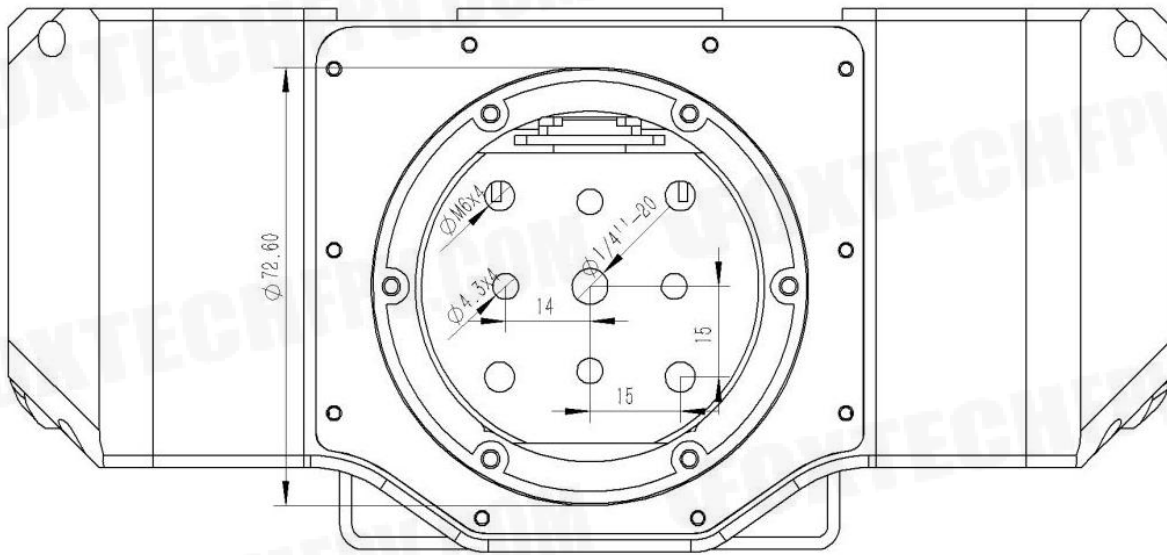

# Appendix B :

## MAVLink support of Foxtech Archer AAT

Archer AAT supports MAVLink V1.1 protocol.

The system requires at least these 2 MAVLink Messages with a 2Hz or higher update rate.

MESSAGE NAME	MESSAGE ID
MAVLINK_MSG_ID_GLOBAL_POSITION_INT	MessageID 33
MAVLINK_MSG_ID_GPS_RAW_INT	MessageID 24

When you set menu [Protocol->ALT=BARO], the Archer AAT uses [MAVLINK\_MSG\_ID\_GLOBAL\_POSITION\_INT.relative\_alt] field for pitch tracking.

When you set menu [Protoco->ALT=GPS], the Archer AAT uses [MAVLINK\_MSG\_ID\_GPS\_RAW\_INT.alt] for pitch tracking.

Which specific ALT setting you need to use depends on the behaviour of your AutoPilot.

Due to the imperfect world of MAVLink you need to pay more attention about the Altitude information of MAVLink. There are about 6~7 places allow the autopilots to send altitude data or barometer data. It's difficult to tell which altitude is exact you need. There are altitudes based on GPS (ASL), based on a baro-altimeter, or based on a combination result of GPS+Baro+Accelerometer.. etc. Different AutoPilots use these altitude fields in the way they understand. That's why we offer this [Protocol.ALT] menu to allow users to choose a altitude field to match their AutoPilot.



## Appendix C :

### How to update Firmware for the Archer

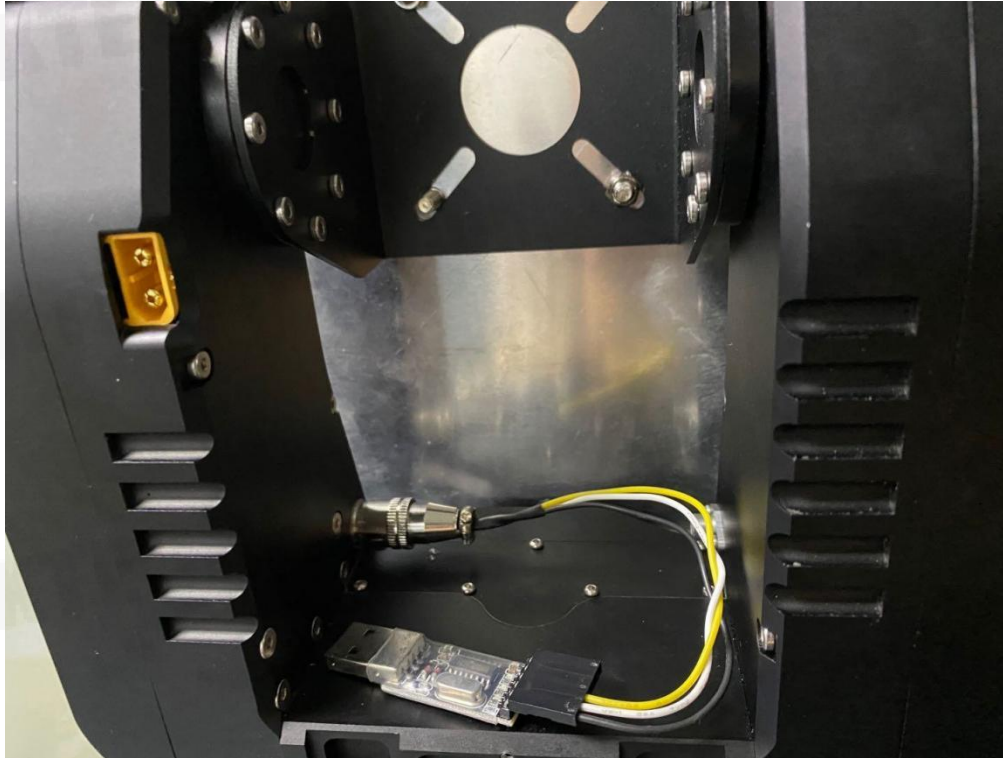

Please connect the update tool to your Archer tracker.

Insert the USB plug to your windows PC.

Install the driver for USB-TTL if necessary:

<https://www.foxtechfpv.com/product/Gimbal/AAT-Gimbal/AAT.zip>

download the MFD FW & update tool (you need .Net 4.0 framework to use it)

<https://www.foxtechfpv.com/product/Gimbal/AAT-Gimbal/AATUSB.rar>

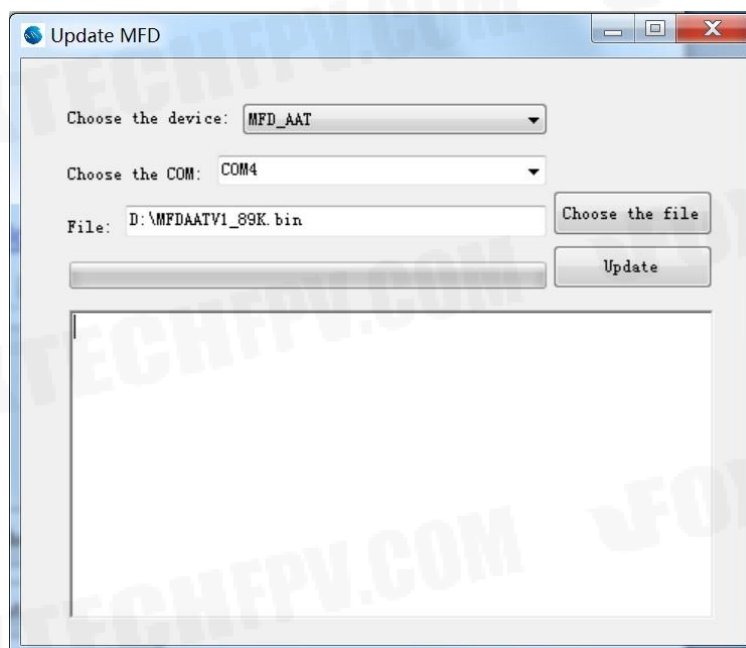

>>> Choose "38400" baudrate for Archer <<<

>>> You need to power on your Archer to update firmwares <<<

Run MFD\_Update.exe. Choose "MFD\_AAT". Choose correct COM port of your computer (The specific COM port number depends on your system). Browse for the firmware on your computer by clicking "choose the file". Then click "Update" button.

A popup window will appear to ask you to confirm the update. Click "YES".

Just wait for a few seconds until the update finishes.

Please check these settings after update:

1. Set Baudrate to the value that you need to work with your gears.
2. Set Current of your 2 motors by menu "MotorCurr". Usually you can use 2000ma for both motors.
3. Calibrate the compass module with menu "CalCompass". If you have an external GPS+compass module please plug it to the tracker before calibration.

This content is subject to change.

Download the latest version from

<https://www.foxtechfpv.com/foxtech-3dm-psdk-cube-oblique-camera.html>

For everyday updates, please follow

Foxtech Facebook page: <https://www.facebook.com/foxtechhobby>

YouTube Channel: [https://www.youtube.com/user/foxtechonline/featured?view\\_as=subscriber](https://www.youtube.com/user/foxtechonline/featured?view_as=subscriber)